

NATIONAL ★ SECURITY SCIENCE

THE FUSION ISSUE

-  **Targeting the future of fusion:**
Breakthroughs support national security
-  **Fusion from then to now:** 100+ years of research support today's advances
-  **Harold Agnew:**
Los Alamos' legendary third director

+ PLUS:

Los Alamos technology
cameos in *Star Trek*

Reflecting on construction of
the National Ignition Facility

Austrian fusion researchers
"live life to the max!"



PHOTOBOMB

Engineers at Los Alamos National Laboratory design and build tiny devices—called targets—that are bombarded (targeted) by particles (such as electrons, protons, or radiation) during experiments. Los Alamos-built targets often are used at Lawrence Livermore National Laboratory's National Ignition Facility (NIF), where scientists are achieving fusion ignition, meaning the experiments create more energy than is put in. In addition to NIF, scientists use targets in tests at the Omega Laser Facility at the University of Rochester and Sandia National Laboratories' Z machine. Los Alamos makes as many as 700 targets a year. Here, a target sits above the letter C on a penny. ★



IN THIS ISSUE

- 2 Letters: The fusion issue** Scientists at Los Alamos National Laboratory have pioneered fusion research for 80 years—and counting.
- 4 Abstracts: Notes and news from around the Lab** Fusion flicks, the fusion fuel cycle, AI for fusion, and more.

FEATURES

- 16 Targeting the future of fusion** At Los Alamos National Laboratory, breakthroughs in fusion research support national security.
 - + Fusion fundamentals
 - + The fusion fandom
- 26 Fusion from then to now** More than a century of research supports today's fusion advances.
- 44 Harold Agnew** Los Alamos' third director remains a legend at the Laboratory today.
- 58 Analysis A mammoth career** Physicist Jeff Paisner oversaw early construction of the National Ignition Facility.
 - + One crane's national security contributions
- 60 The sound of fusion** For an Austrian couple working as physicists, the hills are alive.
- 62 Accolades** The distinguished achievements of Los Alamos employees.
- 63 Looking Back 50 years ago** Los Alamos celebrates America's 200th birthday.



About the cover: Nuclear fusion is the process that powers the Sun and stars. Learn more about the effort to create fusion in a laboratory on p. 16. ★
Photos: Adobe Stock (cover), NASA (above)

THE FUSION ISSUE

Scientists at Los Alamos National Laboratory have pioneered fusion research for 80 years—and counting.



BY MARK CHADWICK
ASSOCIATE LABORATORY DIRECTOR FOR
SIMULATION, COMPUTING, AND THEORY

For generations, researchers at Los Alamos National Laboratory have sought to unlock the promise of fusion energy. The aim has been to reproduce, under controlled laboratory conditions, the same process that fuels the Sun and stars. Success would redefine how the world produces energy, and today's progress rests heavily on scientific breakthroughs first realized at Los Alamos many years ago.

Some of the earliest advances in fusion science date back to the 1940s, during Project Y of the Manhattan Project—later known as Los Alamos National Laboratory. As researchers worked to build the first fission weapons, they also advanced a bold new concept: using a fission explosion to initiate fusion, creating a thermonuclear reaction of unprecedented power. That idea was validated in 1951, when Los Alamos scientists conducted an experiment that produced substantial fusion energy on Earth for the first time.

The next year, scientists further confirmed the viability of thermonuclear fusion and demonstrated the immense potential of fusion-based (thermonuclear)

weapons. Just two years later, the B17 and B24 thermonuclear bombs were incorporated into the U.S. nuclear arsenal for an emergency capability, establishing fusion with fission as a permanent element of the nation's nuclear deterrence strategy.

In this issue of *National Security Science*, you'll explore the past, present, and future of fusion research as it relates to national security. The fusion timeline on p. 26 traces key advances at Los Alamos and beyond over the past 90 years, including the first demonstration of fusion in a laboratory setting, which Los Alamos scientists accomplished in 1958. For a deeper look at the Cold War era, turn to p. 44 for a profile of Harold Agnew, the Laboratory's third director and a central figure in fusion research during the 1950s.

"Targeting the future of fusion" (p. 16) examines ongoing fusion research that enables scientists to recreate specific conditions needed to assess the nation's nuclear stockpile. On p. 60, you'll also meet two Austrian researchers who have devoted their careers to advancing fusion science at the Los Alamos Neutron Science Center.

Readers seeking a more technical perspective should consult Volume 80 of *Fusion Science and Technology*, published by the American Nuclear Society in 2024. An overview appears on p. 11, and the full issue—composed entirely of articles by Los Alamos scientists—is available via the QR code on that page. Together, these articles provide a comprehensive account of the Laboratory's early contributions to fusion research.

As I approach 40 years of service at Los Alamos, fusion continues to inspire me. I hope this issue of *National Security Science* conveys the passion many of us here feel for this remarkable frontier of science. ★

MASTHEAD

EDITOR Whitney Spivey

ART DIRECTOR Brenda Fleming

WRITERS Jake Bartman, Jill Gibson

COPY EDITOR Anne Jones

ILLUSTRATOR Margaret Doebeling

PHOTOGRAPHERS

Lee Anne Dillingham, Ignacio Perez, David Woodfin

EDITORIAL ADVISOR Kimberly Scott

CONTRIBUTORS Mark Chadwick, Maureen Lunn

National Security Science (NSS) highlights work in the Weapons and other national security programs at Los Alamos National Laboratory. *NSS* is unclassified and supported by the office of the deputy Laboratory director for Weapons. Current and archived magazine articles are available at www.lanl.gov/magazine. Unless otherwise credited, all images in the magazine belong to Los Alamos National Laboratory.

To subscribe,
email magazine@lanl.gov,
or call 505-667-4106.

LA-UR-26-22456

Los Alamos National Laboratory, an equal opportunity employer, is operated by Triad National Security, LLC, for the National Nuclear Security Administration for the U.S. Department of Energy under contract 89233218CNA000001.

NSS STAFF SPOTLIGHT



Gerold Yonas, a retired Sandia National Laboratories physicist and vice president, sometimes referred to as the father of pulsed-power fusion, is also the father of *National Security Science* writer Jill Gibson. Here, Gibson and Yonas stand in front of a photo of PBFA-II, a particle beam fusion accelerator (PBFA) that later became the Z machine. Yonas led the development of PBFA and helped lay the groundwork for the pulsed-power technologies that remain central to modern fusion and high-energy-density physics research. ★

FOREWORD

Since the early 1940's, when the first nuclear fission bomb was developed in the then-secret laboratory at Los Alamos, the Los Alamos Scientific Laboratory (LASL) has continued to be one of the world's leading research centers, expanding over the years into many new fields.

One area of intense research at LASL and elsewhere is in controlled thermonuclear fusion. For almost three decades, scientists have been attempting to produce and control fusion reactions in "magnetic bottles."

Another approach to fusion emerged shortly after the invention of the first lasers in 1960. This approach would make use of the compression concepts developed in the nuclear weapons program, but would use intense laser beams to drive spherical implosions of fusion fuel. The work was mainly theoretical until, in 1971, the Atomic Energy Commission greatly expanded the experimental activity to develop powerful short-pulse laser systems.

Thus, in a sense, the laser fusion program is relatively new, with certain weapon technology being used to address peaceful energy needs of man. Though significant laser-initiated thermonuclear fusion "burn" has not yet been achieved, the laser technology is advancing rapidly. Powerful gas lasers, theoretically capable of producing weak fusion burn, should be available within two years. Even more powerful lasers should follow.

This pamphlet is intended to explain the concepts and terminology of laser-initiated fusion in an effort to communicate our work to the public.

H. M. Agnew, Director
Los Alamos Scientific Laboratory
April 1975

■ In 1975, Los Alamos Scientific Laboratory scientists David Freiwald and Thurman Frank wrote and published *Introduction to Laser Fusion*, the abstract of which states "the basic elements and concepts of laser-initiated thermonuclear fusion are presented in an understandable and nontechnical manner." This foreword was written by Laboratory Director Harold Agnew, who is profiled on p. 44. ★

THE INTERSECTION

Science and culture converge in northern New Mexico—and beyond.



Listen up! Check out recent *National Security Science* podcasts by scanning the QR code below. You'll hear audio from a suborbital rocket launch, glovebox training, a high explosives experiment, and more.

On March 3, an unarmed Minuteman III intercontinental ballistic missile (ICBM) launched during an operational test from California's Vandenberg Space Force Base. ICBM test launches, which are years in the making, help ensure the U.S. ICBM fleet is ready, reliable, and effective. If armed, the Minuteman III would carry either the Los Alamos-designed W78 or the Lawrence Livermore-designed W87.



In March, U.S. Navy Admiral Rich Correll, commander of U.S. Strategic Command, visited Los Alamos National Laboratory, where he met with Director Thom Mason and other Lab leadership. They discussed aligning missions and strategic vision, as well as the Laboratory's weapons missions and plutonium pit production.



Heath Watkins (third from the left), a group leader in the Lab's Accelerator Operations and Technology division, has volunteered with the Chamisa Elementary School rocket club for nearly a decade. In March, he assisted sixth graders as they launched rockets from nearby Overlook Park.



Approximately 40 Lab employees and their vehicles participated in the second annual Weapons Facilities Operations Car Show, which featured classic cars, lowriders, hot rods, 4x4 trucks, and even a race car. Attendees voted for their favorite vehicles, and Donald Manzanera's 1985 Buick Regal stood out among the crowd, taking home a third place prize.



Sixty years ago, Los Alamos Scientific Laboratory was designated a registered national historical landmark. Today, this plaque is on display at Ashley Pond Park in downtown Los Alamos.



Los Alamos systems engineer Angelina Garcia studied nuclear engineering at Texas A&M University, and her love for all things nuclear is evident on her Toyota Tacoma, which boasts not only a "fission" license plate but also a "I ♥ nuclear" sign in the rear window.

Fifty years ago, in 1976, the first Cray computer, the Cray-1, was delivered to Los Alamos for a six-month evaluation at no cost to the Lab. Despite the machine's extraordinary speed, it lacked error-correcting memory—the ability to detect changes in data due to mechanical or environmental problems and then correct the data back to its original state. Cray modified subsequent Cray-1 computers to incorporate error-correcting memory, and five of them went to Los Alamos. The Cray-1 was the first commercially successful vector machine, meaning that the computer's processor could execute a single instruction on multiple pieces of data simultaneously.

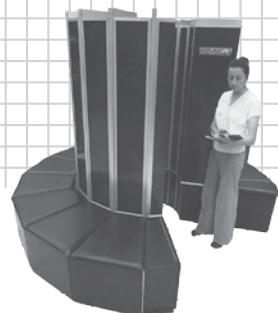

SCIENCE

CULTURE

WHEN AI MEETS FUSION

Large language models tackle challenges in inertial confinement fusion.

BY JILL GIBSON

The next big fusion breakthrough could be made using artificial intelligence (AI). That's according to Los Alamos National Laboratory physicist Radha Bahukutumbi, who is training AI large language models (LLMs) to solve problems and identify new concepts related to inertial confinement fusion (ICF). Bahukutumbi says this approach helps scientists learn more about working with AI while tackling fusion challenges at the same time.

"ICF is a perfect problem—it's a nonlinear, highly-coupled, multi-physics problem grounded in experimentation," says Bahukutumbi, noting that ICF is complex with many variables and available data from real-world experiments. She says LLMs can identify new concepts, improve workflow, and improve fusion target design. "We could have picked an easier problem," she says, "but this will give us results that are relevant to the Lab's national security mission."

The Lab collaborated with the high-performance computing company NVIDIA to train and fine-tune the LLM, named Prospero after Shakespeare's character known to orchestrate events and the Spanish word for success.

Training Prospero was a complex problem with multiple steps. "First, we provided Prospero with existing ICF research,

feeding in 1.3 million documents containing relevant scientific reports and data," Bahukutumbi explains. "Then, we gathered questions from fusion experts from across the Lab and, using those questions, tested its knowledge. After that, NVIDIA used a different LLM to create 33,000 ICF questions. They pulled 600 questions randomly from the pool and gave them to the Lab's ICF experts to review and whittle down to 450. Then, the scientists analyzed Prospero's ability to answer the questions. We have verified that Prospero can continue to understand fundamental science while becoming fusion-aware and will soon put the LLM through its paces here at the Lab. Our next major goal will be to figure out how to feed real-world experimentation data into the LLM."

She says that the ultimate test of Prospero will be to ask it to design a novel ICF experiment. Scientists will then execute the experiment and ask the LLM to improve the result. "If we can use AI to identify new concepts, explore failure modes, test models, and improve predictability and engineering features, we can advance both LLMs and ICF"

Bahukutumbi points out that when Prospero is trained, fine-tuned, and tested, fusion research will still rely on human expertise. "The AI serves as an assistant," she says. "Some people will say it's important when using an AI tool to have a human in the loop, but the truth is we have a human with an AI tool in the sloop."

Bahukutumbi agrees human feedback is essential for LLM training. "You have to keep it honest," she says. ★

■ Bahukutumbi speaks at a conference regarding her work with inertial confinement fusion.

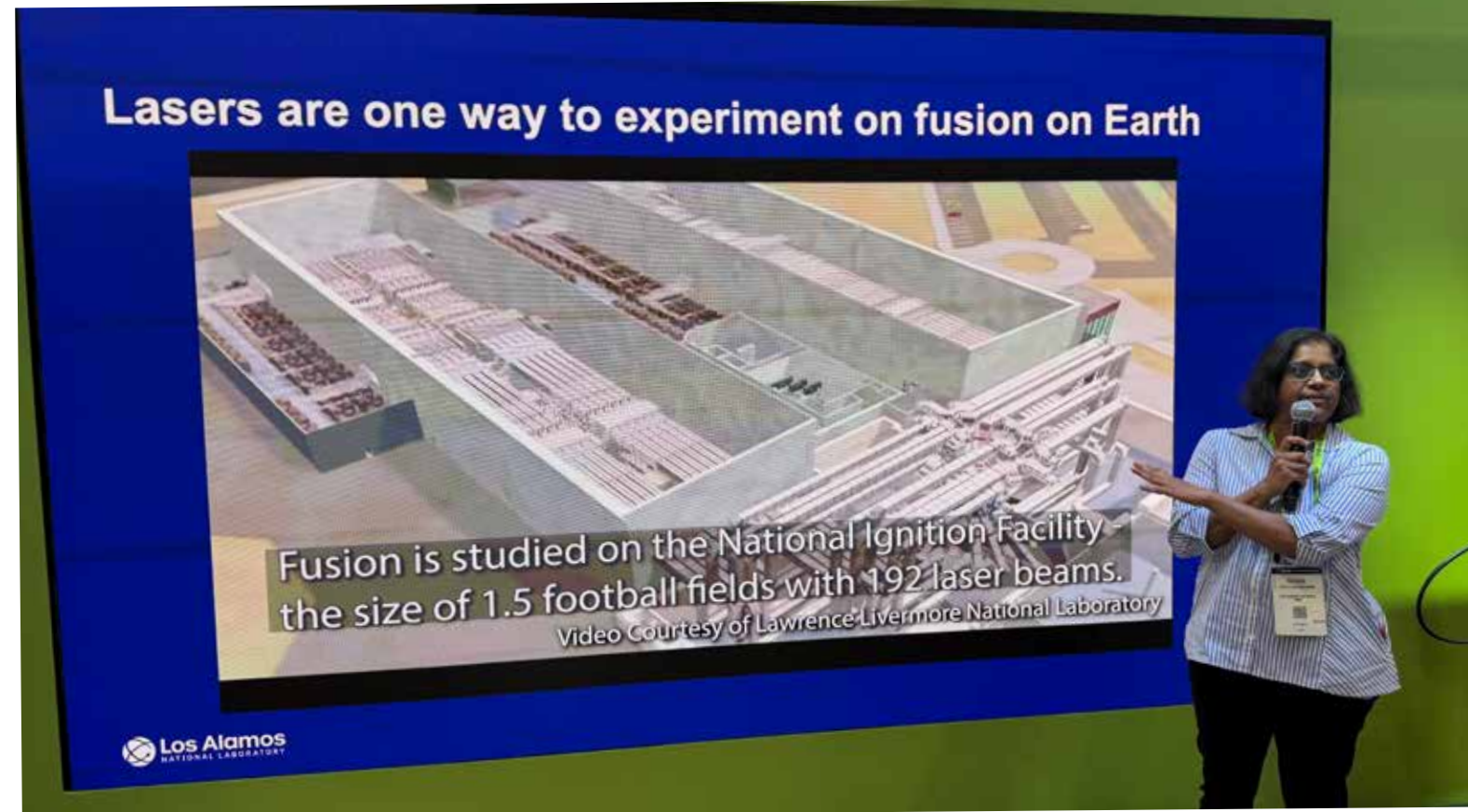



LEADING THE WAY FOR WEAPONS

Charlie Nakhleh brings decades of experience to Los Alamos' top Weapons job.

Charlie Nakhleh is Los Alamos National Laboratory's new deputy director for Weapons (DDW). He succeeds Bob Webster, who retired March 31 after more than 40 years of service to the nuclear security enterprise (see p. 62).

In this role, Nakhleh leads all organizations and programs associated with the Laboratory's Weapons portfolio, totaling approximately \$6 billion and 6,000 employees. Nakhleh guides the strategic alignment of these programs to meet national objectives, ensuring rigorous design, simulation, manufacturing, and certification processes that sustain the nation's nuclear deterrent.

Though only weeks into the job, Nakhleh has already collaborated with partners across the nuclear security enterprise, United States Strategic Command, and policy makers. "We are the lead lab on a number of national security initiatives and play a supporting role in others," he says. "One thing I hope to achieve is better, more integrated interactions at the Laboratory and beyond. Close collaboration is nothing but good."

Among Nakhleh's priorities is working across disciplines at the Laboratory to increase the number and types of experiments that support the assessment of the four weapons systems for which the Laboratory is responsible (the B61 family of bombs and the W76, W78, and W88 warheads), the manufacturing of weapons components, and the development of future weapons systems. "We should all be seized with urgency," he says. "I am extremely focused on trying to bring our experimental and production cadence to where it needs to be to accomplish our mission at the speed of relevance."

Since joining the Lab in 1996, Nakhleh has served in several leadership roles, most recently as the associate Laboratory director for Weapons Physics (ALDX), where he oversaw the Lab's weapons physics and design portfolio, dynamic experimentations, and multiphysics computational simulations. Prior to leading ALDX, Nakhleh was the executive officer for Weapons programs and the division leader for the X Theoretical Design division. From 2007 to 2013, Nakhleh spent six years at Sandia National Laboratories, where he led target design and analysis efforts for inertial confinement fusion (ICF) and high-energy-density physics experiments on the Z machine pulsed-power facility (see p. 16). Before joining Sandia, he was a member of the Applied Physics Division at Los Alamos,

■ Prior to accepting the position of deputy director for Weapons, Nakhleh served for six years as the associate Laboratory director for Weapons Physics.



■ Charlie Nakhleh (left) discusses updates to the Lab's Dual-Axis Radiographic Hydrodynamic Test facility. "One of the nice things about my job is that I get to see the continuous thread between the micro and the macro: how discussions about facilities and experimental and computational equipment and work feeds into, and derives from, discussions about national posture, strategy, and challenges," Nakhleh says. "For me, it's all of a piece." Learn more about these updates on p. 13.

where he made significant contributions to weapons physics and design. "Throughout his career, Charlie has exemplified the integrity, rigor, and sense of purpose that define Los Alamos," says Lab Director Thom Mason.

Nakhleh's research interests span nuclear weapons design and physics, ICF, high-energy-density physics, and applications of Bayesian inference techniques. Nakhleh earned doctorate and master's degrees in physics from Cornell University and a bachelor's degree in physics

from the University of Virginia. He is also a graduate of the Laboratory's Theoretical Institute of Thermonuclear and Nuclear Studies (TITANS) program.

Nakhleh says he's continually inspired by the Laboratory's scientific and technical pursuits that exhibit creativity, innovation, excellence, and responsiveness. "Whenever I see a piece of work exemplifying those traits from anyone in the Laboratory, I think to myself 'this is what a national lab is all about. This is why we're here.'" ★



■ Nakhleh says he draws a great deal of leadership inspiration from his years spent working for another Charlie—former Los Alamos Director Charlie McMillan (left).

■ In August 2000, National Nuclear Security Agency (NNSA) administrator General John Gordon (right) talks with NNSA Chief of Defense Nuclear Security John Todd and Nakhleh, who was then part of the Lab's Thermonuclear Applications group.



Credit: Paramount

Starship Enterprise Chief Engineer Montgomery "Scotty" Scott (Simon Pegg) debates with Captain James Kirk (Chris Pine) in front of the starship's warp core (the NIF target chamber) during the 2013 filming of *Star Trek into the Darkness*.



Scan the QR code to learn how *Star Trek* inspired some Los Alamos employees to pursue careers in science.

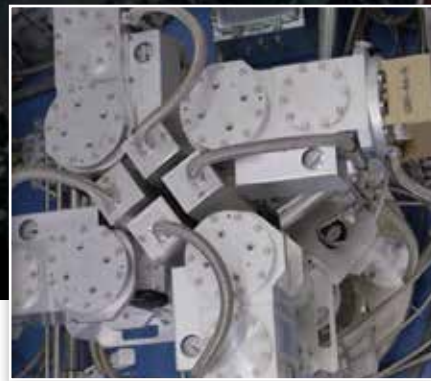

FROM FUSION SCIENCE TO SCIENCE FICTION

Los Alamos technology has a cameo in *Star Trek*.

BY JILL GIBSON

When Los Alamos National Laboratory physicist and fusion researcher Kevin Meaney plans a family movie night, he might choose the 2013 film *Star Trek into the Darkness*. What motivates his choice is not a love of *Star Trek*, science fiction, or old movies. Instead, he's hoping to catch a glimpse of Los Alamos–designed technology on screen.

Several scenes in this *Star Trek* movie were shot at the National Ignition Facility (NIF), where Los Alamos scientists conduct fusion experiments. NIF, located at Lawrence Livermore National Laboratory, was used to represent the Starship Enterprise's warp core drive, serving as a backdrop for several scenes. The film crew obtained Department of Energy permission to spend eight days shooting at NIF.

For Meaney and his Los Alamos colleagues, the best parts of the movie feature key diagnostic equipment in the background. "Los Alamos designed the gamma detectors that you can see in the target chamber in the movie," says Meaney, noting that the Los Alamos–designed detector appears directly behind two main

characters during one scene. "The movie studio spruced up the laser to make it look cool and added some LED lights to our detector to make it glow," he adds.

Meaney explains that the Laboratory has a strong history of designing diagnostic equipment for NIF. Lab scientists first created the gamma reaction history diagnostic, which appears in the movie, and later refined it to develop the gas Cherenkov detector, which was fielded initially at the Omega Laser Facility in Rochester, New York, and then later moved to NIF.

Gamma diagnostics play a critical role in fusion experiments because gamma rays are produced at the exact moment a fusion reaction occurs. By measuring them, scientists can determine when fusion happened and how long the fusion burn lasted. At the same time, measuring neutrons, the main product of fusion, allows scientists to determine the amount of energy released in the fusion reaction, so both neutron and gamma diagnostics play a starring role in fusion research.

Neutrons were also key to a prank some of the actors in *Star Trek into the Darkness* played on fellow cast members, telling them they needed to apply a special protective cream while filming at NIF.

"They convinced me before I got there that there was this neutron cream you had to dot on your face to protect against all the neutrons that were flying around in the air," said actor Benedict Cumberbatch. "And you know, who am I to question science?" Of course, NIF was not in operation during the filming and there was no danger from stray neutrons, but it's a fun story for Los Alamos scientists to tell during movie night. ★

FUSION FLICKS

For decades, Hollywood has used fusion to "power" its blockbusters.

BY JAKE BARTMAN

Recent fusion-energy research at Los Alamos National Laboratory is helping bring commercial fusion power reactors, which scientists have been working to develop for more than 70 years, closer to reality. But there's one place where fusion reactors have long been taken for granted: Hollywood.

For decades, screenwriters have used the concept of fusion reactors to create compelling sci-fi stories. Both *Star Wars* and *Star Trek*, for example, feature starships powered by fusion, and movies such as *Chain Reaction* (1996) and *The Saint* (1997) use the invention of new fusion-reactor technologies to drive their plots.

Of course, the reactors in Hollywood movies aren't intended to be wholly realistic. Yet the ways in which these fusion reactors differ from real-world reactors can be instructive. Here, *National Security Science* revisits three iconic movies in which fusion reactors play a key role, separating fact from science fiction.



Spider-Man 2 (2004)

In *Spider-Man 2*, nuclear physicist Otto Octavius (played by Alfred Molina) builds a tritium-powered fusion reactor that goes awry during a demonstration. The accident affixes a set of artificial intelligence–controlled robotic arms to Octavius's back, which turn him into the evil Doc Ock, who embarks on a crime wave as he seeks to rebuild the reactor.

The design of Octavius' reactor is visually inspired by real-world ideas about magnetic confinement, which involves using magnetic fields to contain a plasma. However, in *Spider-Man 2*, Doc Ock's reactor lacks the shielding and other infrastructure that makes such reactors stable and safe to use (for example, by confining the neutrons that would be produced in a fusion reaction, which without shielding could kill onlookers in seconds or minutes).

The reactor in *Spider-Man 2* is also much smaller than a real-life reactor would be. Moreover, the reactor involves the creation of a "protostar"—a miniature star that pulls objects into itself via its gravitational field—in a way that no real-life fusion reactor would. Instead, real magnetic-confinement reactors are generally designed to contain plasma in toroidal (donut-shaped) or linear configurations, and they lack strong gravitational fields.



IRON MAN (2008)

Early in *Iron Man*, arms mogul Tony Stark (played by Robert Downey, Jr.) is kidnapped by criminals who order him to build them a missile. Rather than comply, Stark creates a miniature fusion reactor with a palladium core. The reactor is then installed in Stark's chest, and Stark uses it to power a flying suit of armor, which enables his escape from captivity.

Like the reactor in *Spider-Man 2*, *Iron Man's* reactor draws on ideas about magnetic-confinement fusion (in this case, the reactor appears to be a miniature tokamak—a type of toroidal fusion reactor). Also like in *Spider-Man 2*, the *Iron Man* reactor is much too small: Stark says in the film that the reactor in his chest produces three gigajoules of energy per second—a power output that, in the real world, would likely require a building-sized reactor.

Furthermore, real-life reactors don't rely on palladium to the extent that Stark's does. Palladium was a notable component in historical cold-fusion research, but it isn't a major part of modern fusion reactors. However, a team of Canadian researchers did recently find that palladium can modestly boost fusion rates when incorporated into small experimental reactors, pointing toward potential future uses for the element in fusion-reactor design.

In this sense, Stark's palladium reactor could one day seem more realistic to science-minded viewers—at least when compared with a flying suit of armor.



BACK TO THE FUTURE PART II (1989)

This sequel to the iconic original sees inventor Dr. Emmett "Doc" Brown (played by Christopher Lloyd) arrive, via his time-traveling DeLorean, in 1985, where he persuades everyman Marty McFly (played by Michael J. Fox) to travel with him to 2015. There, the pair endeavor to stop McFly's son from making a catastrophic mistake.

Brown's DeLorean is powered by a portable fusion reactor with the brand name "Mr. Fusion," which converts garbage—banana peels and a beer can, for example—into energy. Rather than trash, real-world fusion reactors rely on high-purity hydrogen isotopes, such as deuterium and tritium, for fuel. Currently, researchers at Los Alamos are designing and fabricating tiny capsules containing deuterium and tritium that are bombarded with lasers at the National Ignition Facility (NIF) to produce fusion, answering important questions about the fusion process and informing reactor design (see p. 16).

Unlike NIF and planned fusion reactors, the Mr. Fusion reactor in *Back to the Future II* appears to use cold fusion—fusion that takes place at near room temperature (rather than at hundreds of millions of degrees Celsius). Although cold fusion was a matter of much discussion for a brief period in the late 1980s, today, the process is thought impossible by most scientists. ★



■ Seventh grader Aidan McMillan spent four years building a nuclear fusion device that was verified by Los Alamos researcher Robert Dwyer.



help, he verified his success just a day before he turned 13.

McMillan says setting a record was never his goal. “It was always just about finishing the fusor,” explains the seventh grader, who also enjoys hanging out with friends, playing in his school band, and going rock climbing. “I kind of just picked a project, said I want to do this thing, and then learned about it and gained a lot of skills. For me, it’s about the skills that I learned.”

McMillan and his parents live in Dallas, Texas. Neither his mother

nor his father has a scientific background, but they share a commitment to helping their son learn. McMillan’s mother, Sherin Foroudi, remembers watching Aidan as a fourth grader teaching himself physics and nuclear engineering. “There were some things he read that he had to Google every word,” she says. “He spent a lot of time really understanding it conceptually before he started building anything.”

McMillan built the fusor under adult supervision at the Dallas Makers Space and Launchpad Incubator, a makerspace for teens that his parents founded. The device uses high voltage and a vacuum chamber to create the conditions for fusion. “Aidan was at the makerspace all of his weekends and holidays,” his mother says, adding that she spent a significant amount of her chaperoning time knitting. “I remember one Thanksgiving break when he was just there all day, every day, but I drew the line at Thanksgiving. I was like, absolutely not.”

But despite that enforced break, McMillan’s parents supported the project, purchasing most of the parts for the fusor on Ebay and obtaining deuterium gas, a hydrogen isotope that serves as the fusion fuel, from an industrial supplier.

“The device uses electric fields to heat and accelerate deuterium gas to fusion conditions in which the atoms come together and combine—or fuse—producing neutrons,” Dwyer explains. “You need vacuum chambers, vacuum pumps, and a high voltage supply that creates an electric field,” he says.

FIRST IN FUSION

A Los Alamos researcher helps a teen set a world record.

BY JILL GIBSON

Most eight-year-olds build things out of Legos. Aidan McMillan decided to build a nuclear fusion device.

Four years later, his homemade fusor began producing neutrons—the signature of fusion—there was only one problem: proving it. For that, he turned to Los Alamos National Laboratory.

The researcher who answered the call for help, Robert Dwyer, recognized something familiar. As a teenager, he had made a similar fusion device himself. “We got an email from this kid’s mom reaching out to Los Alamos to see if there was anyone who had the expertise to verify his claim and help certify his device,” Dwyer says. “It just so happens; I had built one of these machines before.”

Dwyer started work on his fusor at age 15 and achieved fusion at 17. McMillan reached his goal by the time he turned 11 and decided to go for a spot in the Guinness Book of World Records as the youngest person to accomplish this feat. With Dwyer’s

When electricity passes through the deuterium, it strips away electrons, leaving behind positively charged ions and forming a plasma—a glowing cloud of charged particles. “The deuterium plasma is purple, but that purple glow doesn’t show the fusor actually works,” McMillan says. He explains that the electric field pulls the charged particles together, so they collide, slamming together to produce energy and release neutrons. “The neutron generation proves the fusor works,” he says.

To submit his achievement for a world record, McMillan needed two specialist witnesses. Dwyer knew exactly who to enlist for the second witness role. He turned to Carl Willis, the scientist who had helped Dwyer build his own fusor decades ago. Willis, a University of New Mexico nuclear engineering professor who had also worked at Sandia National Laboratories, traveled to Dallas with a specialized neutron detector. As Dwyer watched remotely, McMillan flipped the switch.

“I concluded that Aidan’s fusor was producing at least 150,000 neutrons per second and perhaps as many as 220,000 per second,” Willis says. “While Aidan’s system is not close to setting any records for most efficient or highest neutron output, it did perform easily measured deuterium to deuterium fusion while I was visiting.”

Willis says he was happy to make the trip to Dallas to support McMillan. “I benefited from expert mentorship in my hobbies as a young person, and I believe these formative experiences were essential in developing my passion, my skill set, and my professional network as a mature nuclear engineer. Creating these opportunities for the next generation is therefore important to me because I know first-hand how valuable they are.”

Willis and Dwyer also checked to make sure McMillan understood the safety precautions needed for building and operating the fusor. “Nuclear physics is often popularly regarded as an impossible pursuit for kids—a perhaps-dangerous activity that is the exclusive domain of secure, high-budget labs,” Willis explains. Although McMillan’s device does not generate dangerous radiation, it uses high voltage electricity, which can be dangerous when used incorrectly.

“There’s significant electrical hazards associated with building what’s essentially like a mini particle accelerator,” Dwyer says. “I made sure to check that things were properly insulated and that there weren’t wires or things hanging out where people could touch them. Aidan was also working with people who had a bit of a knowledge of those electrical hazards as well and could adequately supervise him and supervise the effort to make sure it was safe.”

As for McMillan, he describes the process of building the fusor as both fun and frustrating. “It came together, and then it was fun for a bit. Then there was more frustration and a lot of work, but it ended up being worth it,” he says. One aspect of the achievement he’s not as sure about is the attention he has received from his classmates. “Kids say things like, ‘Hey Aidan, did you split the atom today?’ and I’m like, ‘No—that’s actually the wrong thing entirely.’ ★

FUSION SCIENCE AND TECHNOLOGY

An international research journal of the American Nuclear Society

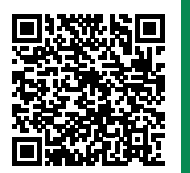

American Nuclear Society

AN ACADEMIC APPROACH

A special issue of *Fusion Science and Technology* highlights early fusion research.

BY WHITNEY SPIVEY

In the early days of the COVID-19 pandemic, initially working from the isolation of his home office, Los Alamos National Laboratory scientist Mark Chadwick led an effort to bring together colleagues to document new research on Manhattan Project experiments. The resulting collection of 46 papers was published in the Laboratory’s *Weapons Review Letters* classified journal; 23 of those papers were published as a special open-access issue of the American Nuclear Society’s *Nuclear Technology* journal.

Five years later, Chadwick launched a similar initiative with a different focus. This time, he invited colleagues to examine early fusion research at Los Alamos, particularly its role in the development of thermonuclear weapons. That effort produced 35 papers published in the *Weapons Review Letters*. Fourteen of those articles were unclassified and subsequently appeared in Volume 80 (2024) of the American Nuclear Society’s *Fusion Science and Technology* journal (see QR code).

“Much of the nuclear fusion technical history presented herein has not been previously reported,” Chadwick and his coauthor, Cameron Reed, write in their introduction. “The papers describe aspects of fusion science from this period, including shock hydrodynamics, electron-radiation coupling, and nuclear physics, such as the discovery of resonances in both the DT [deuterium-tritium] cross section and the lithium tritium-breeding cross section.”

According to Chadwick, the response to both journal issues has been overwhelmingly positive. In addition to presenting new findings, readers have appreciated the opportunity to revisit the history of early fusion research. “While the papers in this issue are testament to the vigorous level of fusion research carried out during and after the Manhattan Project,” Chadwick wrote, “the subsequent course of events makes it easy to forget just how speculative the idea of a fission bomb was in the fall of 1941—let alone a fusion device.” ★

FUELING THE FUTURE OF FUSION

Los Alamos National Laboratory scientists sharpen their understanding of the fusion fuel cycle.

BY JILL GIBSON

Tritium is a rare radioactive isotope of hydrogen that is perhaps best known for illuminating watch faces and exit signs. When combined with deuterium, a nonradioactive isotope of hydrogen, tritium also plays a key role in nuclear fusion—both for weapons applications and for possible production of fusion energy.



■ The Weapons Engineering Tritium Facility is dedicated to safely understanding how tritium, the key component in the fusion reactor fuel cycle, behaves, ages, and interacts with other materials critical to nuclear weapons. Recent upgrades are enabling new research into tritium's interactions with materials inside nuclear weapons, and proposed additions to the facility could play a role in the development of fusion energy.

For many decades, Los Alamos National Laboratory scientists have researched the process of using tritium to power nuclear fusion reactors. The Lab's expertise in understanding this fusion fuel cycle could play a crucial role in bringing fusion energy to the electrical grid.

Los Alamos chemical engineer Scott Willms has dedicated his career to studying tritium processing and the fusion fuel cycle. He recently returned to the Lab after spending 14 years at ITER, a collaborative international effort to build the world's largest tokamak (magnetic confinement device) and explore the feasibility of nuclear fusion as an energy source. Now, Willms is focusing on Los Alamos-designed systems for fueling fusion reactors. He says that understanding the fusion fuel cycle is a key component of creating viable fusion energy.

"In both magnetic and inertial confinement fusion reactor systems, you are not going to burn more than 3 percent of the tritium each time it passes through the reactor," Willms says. "Tritium is extremely limited, so, for fusion reactors to be effective, we must understand how to clean up tritium and put it back in."

Willms says this work first began in the early 1980s with Los Alamos' Tritium Systems Test Assembly (TSTA), a facility dedicated to the development and demonstration of technologies needed for developing fusion powered reactors. Los Alamos scientists used TSTA to separate isotopes and remove impurities using a process called cryogenic distillation along with a specially designed membrane. "We demonstrated all the systems that you need to clean up the fuel quickly and get it back in the reactor."

The Department of Energy decommissioned TSTA in 2004, but fusion fuel cycle research continues at Los Alamos' Hydrogen Processing Lab (HPL). Today at HPL, scientists test new technologies related to the fusion fuel cycle.

David Dogruel is one of the scientists leading that research. "We are developing and testing the technology using hydrogen and deuterium instead of the fusion fuel of tritium and deuterium because hydrogen behaves identically to tritium but is not radioactive," Dogruel says. "We can validate the evolving technology and integrate computer modeling to guide and refine both future experimental work and the design of fusion fuel-processing systems. One of the next steps will be to conduct experiments using tritium."

Dogruel points out that Los Alamos scientists have the benefit of experience working with tritium since the Manhattan Project and have the necessary facilities, such as the Lab's Weapons Engineering Tritium Facility, the nation's primary tritium research institution. "You can't go to Tritium Mart, pick up some tritium, and start playing with it," he says. "The U.S. national labs have the scientific leadership in tritium and are the only place we can do this."

Willms says that the Lab's expertise and its commitment to working with private companies (p. 14) to support fusion research are a big part of what brought him back to Los Alamos. He and Dogruel say they are excited about the future of their work.

"Los Alamos has an incredible history of doing very hard things," says Dogruel, adding, "Many of those things are related to fusion and the fusion fuel cycle." ★

UPGRADES UNDERWAY

Major maintenance and modernization begin at the Dual-Axis Radiographic Hydrodynamic Test facility.

BY JILL GIBSON

The National Nuclear Security Administration's (NNSA's) flagship radiography machine is getting an upgrade. From December 2025 to March 2026, the Dual-Axis Radiographic Hydrodynamic Test (DARHT) facility, located at Los Alamos National Laboratory, underwent the first round of projects that will maintain and modernize the aging accelerators used to capture images of mock weapons implosions and to conduct focused experiments on weapons materials and components.

"DARHT is the keystone facility in weapons certification," says George Laity, who heads up the DARHT Capability Expansion (DCX) project office. We need to ensure that DARHT is maintained, sustained, and modernized to meet that goal and future mission needs."

Laity notes that during this period of upgrades, all DARHT experiments were halted. "Our plan is to do five to seven maintenance and replacement projects each year over several years," he says. DARHT staff refer to this pause from their regular experiment schedule as "the DCX sustainment outage," but it is far from rest and relaxation. During the recent outage, the facility buzzed with activity from multiple updates underway all at once.

Engineer Kyle Fiordalis, who leads one of the upgrades, says he is the same age as DARHT—27. In accelerator years, that's middle-aged, but, although DARHT is aging, it faces growing expectations. Currently, the Laboratory conducts between four and six major experiments at DARHT each year; however, NNSA is calling for an increase to at least eight experiments a year.

One of the biggest makeovers during the outage was a complete refresh of the DARHT Detection Chamber or DDC. "The DDC is the brain of DARHT," says Fiordalis. "We replaced the electronics—basically doing brain surgery on some level," he says.

Another project was the addition of a multi-pulse test line that scientists can use to conduct research and collect data without interrupting other experiments. "We are diverting the accelerator beam, actually bending the beam 90 degrees using a first-of-its-kind application of large, specially designed magnets," says physicist Alex Press, who led this update. "This capability will allow multiple experiments to run when the beam isn't being used for DARHT's primary mission, hydrotests."

Refurbishing an accelerator cell, moving equipment, installing more cameras, plus regular upkeep tasks were just some of the many activities that kept staff from several Lab divisions busy during the four-month maintenance and modernization period. "We've collaborated well across organizations and learned quite a bit about how to do things in a coordinated way," Laity says. "Our strategy describes a decadal vision of all the improvements we want to make to DARHT, so this is just the first step." ★

■ Engineering technologist Robbie Brooks is one of the many Lab employees from multiple areas who collaborated on recent upgrades at the Dual Axis Radiographic Hydrodynamic Test facility.





■ The Feynman Center in downtown Los Alamos. Photo: Los Alamos County

COLLABORATION DRIVES FUSION INNOVATION

Los Alamos partners with private companies to accelerate fusion energy.

BY JILL GIBSON

In the past 10 years, numerous privately funded companies have emerged with the goal of producing commercial energy from nuclear fusion. Now, many of these startup companies are drawing on Los Alamos’ fusion expertise. Kathleen McDonald helps facilitate these partnerships in her role as a commercialization manager for the Lab’s Richard P. Feynman Center for Innovation. The center helps businesses and organizations work with Los Alamos to turn research into practical products and solutions.

“Tremendous capabilities exist at the Lab to support the fusion energy community,” McDonald says. “Our legacy of national security–related fusion research positions Los Alamos as an ideal partner in topics around materials for fusion, fuels, diagnostics, target fabrication, and more.” She explains that Los Alamos supports companies by sharing advice and technical approaches based on the Lab’s decades of research. “Our goal is to provide a path for the Lab to collaborate with industry partners on research and development efforts that will benefit the nation’s economic competitiveness,” she says, adding, “Los Alamos can provide technical expertise that, in collaboration with technical experts at the companies, enable concepts to be advanced from theory to practical application.”

Often, these partnerships are formalized through Cooperative Research and Development Agreements or CRADAs. So far, the Lab has established three CRADAs with private fusion companies and two more are in the works. McDonald says Los Alamos has also formed strategic partnership projects in fusion-related technology with other companies. “Each company is pursuing a different approach to fusion or is focused on a different aspect of technology,” she says.

John Kline, the Fusion Energy Sciences program manager at Los Alamos, is working closely with many of the private companies to build relationships and enable success. “These companies are developing capabilities that support our national security mission,” Kline says. “By engaging with industry, we can make research and development economical and viable,” he adds, noting that private companies often work at a faster pace and pursue different areas of research than the national labs.

A recent memorandum signed by deputy Laboratory directors Bob Webster and Pat Fitch emphasized the importance of these partnerships. The memorandum states, “it is in the interest of LANL and the nation for LANL to actively engage with private fusion companies to collaboratively drive advancements in fusion understanding and modeling, to benefit from access to cutting-edge experimental facilities for our mission, and to tap into a skilled workforce now and in the future.” The memorandum goes on to explain that industry partners can contribute agility, innovation, and commercialization pathways, while the Lab will provide mission alignment, infrastructure, and credibility. The document notes that several private sector companies are proposing to develop high yield fusion facilities that the Lab could potentially use for mission-relevant experiments.

Kline points out that the companies currently working with the Lab each have different approaches and culture. He also says that the more people working on fusion research, the faster the technology will evolve and improve.

“More companies pursuing fusion research means more data,” Kline says. “The more data we can get, the better our science will be.”

Kline feels excited and optimistic about these new relationships. “Private companies have disruptive approaches and will test new ideas and engage in creative problem-solving. Working with them helps further the development of fusion energy and help the Lab fulfill its national security mission. Together, we will grow. ★

MODELING THE FUTURE OF FUSION

A project at Los Alamos National Laboratory envisions the systemic effects of a transformative technology.

BY JAKE BARTMAN

Private companies around the world are racing to develop commercial fusion power reactors, building on advances such as the 2022 achievement of fusion ignition at the National Ignition Facility in California. But although the development of fusion power reactors could bring prosperity—perhaps even ushering in an era of electricity that is “too cheap to meter,” as Atomic Energy Commission Chair Lewis Strauss famously put it—the technology could bring new dangers, too.

“Fusion energy is qualitatively different from fission energy in its resource needs and security implications,” says Chris Danly, a scientist at Los Alamos National Laboratory. “Even though we don’t know yet exactly what a fusion power plant would look like, we should start thinking about the implications now.”

For example, if fusion power reactors are developed and become widespread, energy abundance could result and international conflict over resources might diminish. On the other hand, hydrogen isotopes deuterium and tritium—the fuels for most planned fusion reactors—aren’t covered by current safeguards regimes, which focus on materials such as uranium and plutonium. That fact could lead to new proliferation risks.

Danly is leading a project that aims to help characterize the opportunities and risks that fusion power presents. To do this, he is developing an add-on to Pacific Northwest National Laboratory’s Global Change Analysis Model (GCAM). GCAM allows users to envision, on a hundred-year timescale, how changes in factors such as population, income, or technology cost can affect crop production, energy demand, water use, and more in regions around the world.

By developing an add-on to GCAM that will allow researchers to envision the possible effects of fusion power on linked

energy-economic-political systems, Danly is advancing the GCAM framework to model scenarios in a way that informs funding decisions, supports contingency planning, and bolsters threat reduction in the United States.

For instance, the add-on could help researchers and decision-makers understand what would happen if the United States developed fusion power first, or, conversely, if another country—China, for example—did. The effects of other factors, such as the ease or expense of constructing different proposed types of fusion reactors, could also be incorporated into the GCAM add-on to model both risks and opportunities for the United States and the international community.

“Nuclear nonproliferation and global-security issues are a consideration for fusion technology, and they’re things that Los Alamos has a lot of experience in,” Danly says. The Laboratory’s experience with modeling large-scale phenomena, such as the spread of conflict or disease, can support this research. Likewise, Los Alamos’ experience in fusion research, which dates to the Manhattan Project in the 1940s, means that Laboratory researchers can impartially evaluate the possible success or failure of private fusion projects, informing Danly’s work in turn.

“Los Alamos has been working on fusion since its inception, so we have historical experience with looking at nuclear technologies and how they change the world,” Danly says. “Our ability to step back and look at the big picture is significant.”

Danly’s own experience reflects the breadth of the Laboratory’s fusion research and development. Having spent the past 10 years researching a specific ion temperature–measurement technique, Danly’s shift to examining the large-scale effects of fusion energy allows him to reconcile a longstanding interest in international relations with his nuclear physics expertise.

“With this project, I’ve gone from studying one specific plasma variable measurement to really trying to look at the whole world,” Danly says. “That’s the kind of thing you can do at Los Alamos.” ★

■ A Los Alamos research project is attempting to model the possible systemic effects of fusion power. Photo: NASA



■ In an inertial confinement fusion experiment, lasers heat a tiny capsule containing fusion fuel (two forms of hydrogen) suspended inside a cylindrical x-ray "oven" called a hohlraum, causing an implosion that compresses and heats the fuel to extreme temperatures and densities until the hydrogen atoms fuse, starting a fusion reaction.

Targeting the future of FUSION

At Los Alamos National Laboratory, breakthroughs in fusion research support national security.

BY JILL GIBSON

For a few trillionths of a second

in June 2025, a tiny capsule of fusion fuel—a mix of deuterium and tritium gases—just 2 millimeters across, burned at nearly 260 million degrees Fahrenheit—about 10 times hotter than the core of the Sun. “During this brief time frame, our experiment was the hottest point in the solar system,” says physicist Ryan Lester, who was among the Los Alamos National Laboratory scientists who conducted the experiment at the National Ignition Facility (NIF) at Lawrence Livermore National Laboratory in California.

Lester’s work often involves inertial confinement fusion experiments at NIF where, in 2022, scientists at Livermore first achieved ignition—when a fusion experiment produces more energy than delivered to start the reaction. In addition to being extremely hot, ignition represents a crucial step forward in using fusion for national security research, harnessing fusion energy for commercial power, and understanding the process that fuels the Sun and stars.

The fact that fusion research is occurring at the nation’s nuclear weapons laboratories is not coincidence. Although Los Alamos scientists pursue the basic physics knowledge and energy applications of fusion, national security is at the heart of their work. That’s because understanding fusion enhances scientists’ ability to design, certify, and assess the nation’s nuclear deterrent, which currently consists of six thermonuclear weapons.

Nuclear weapons: a primer

Fusion plays a powerful role in the design and operation of modern thermonuclear weapons, in which a fission reaction triggers a fusion reaction. In the first stage, high explosives compress fissile material (usually plutonium) to start a fission reaction that releases x-rays. The x-rays compress and heat the secondary stage, which contains the fusion fuel, causing it to ignite. A fireball hotter than the center of the Sun forms nearly instantly, releasing kilotons of energy.

Of the six thermonuclear weapons systems in the active nuclear stockpile, Los Alamos is responsible for four

■ Scientists use complex 3-D simulations like this one to predict what will happen during an inertial confinement fusion experiment.

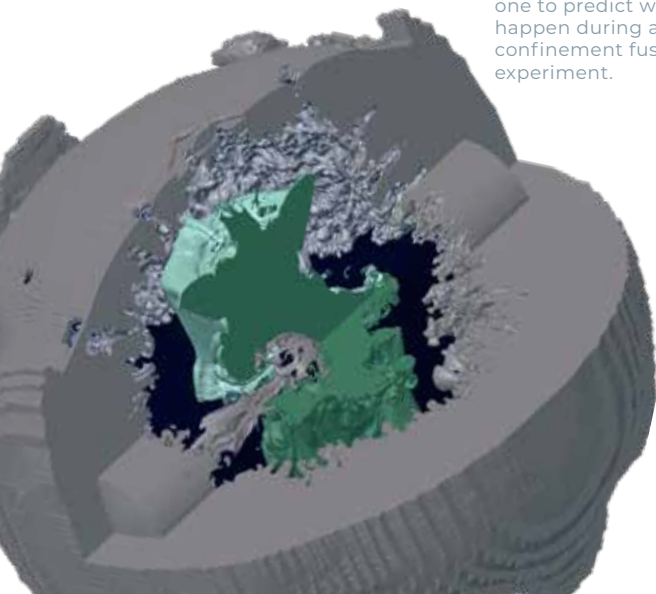

systems (the B61 bomb and the W76, W78, and W88 warheads); Livermore is responsible for two (the W80 and W87). Los Alamos and Livermore are also developing future systems, including the forthcoming W93, which will be carried on submarine-launched ballistic missiles. A third institution, Sandia National Laboratories, supports all active and future weapons.

“I see fusion research as a way to serve my country,” Lester says. “We are working on national security challenges and ensuring the safety of our deterrent. Along the way, we’re also building the foundations for fusion energy and deepening our understanding of astrophysical phenomena like how the stars work and how radiation moves through extreme environments. Both are invaluable byproducts of that work.”

Diving into diagnostics

Los Alamos National Laboratory and fusion have a history. “Los Alamos is the birthplace of multiple fusion breakthroughs,” says Mark Chadwick, the Lab’s associate director for simulation, computing, and theory. “The Lab’s extensive legacy in fusion research has paved the way for the recent ignition achievement and other scientific success.”

Many of the first advances took place in the 1940s during Project Y of the Manhattan Project (what would later become Los Alamos National Laboratory). In 1951,



Fusion Fundamentals

What is fusion? And how can it be created?

Nuclear fusion occurs when two atomic nuclei combine to form a new nucleus. The process releases energy because the total mass of the resulting single nucleus is less than the mass of the two original nuclei, so the leftover mass becomes energy. Einstein’s equation ($E = mc^2$), explains why this process occurs.

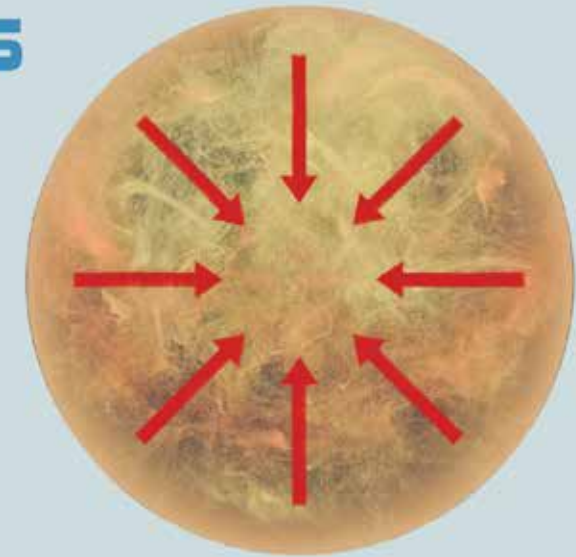
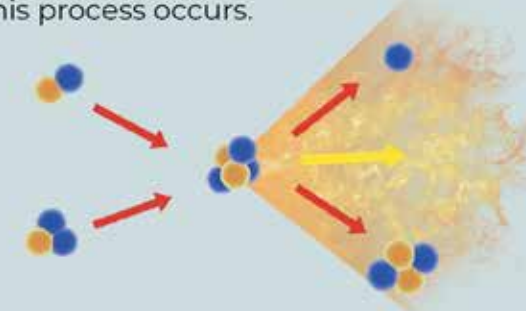

Los Alamos scientists conducted an experiment that marked the first human-created fusion reaction.

“That experiment was only the second time deuterium-tritium fusion has occurred in the universe—the first being during the first few minutes after the Big Bang, when primordial nucleosynthesis produced most of the universe’s helium,” says physicist Kevin Meaney. “Today, at NIF, we recreate those fusion conditions nearly every week—on a very small scale.”

Meaney points out that ever since that first fusion demonstration, largely as part of its weapons work, the Laboratory has worked tirelessly to improve fusion diagnostics—the tools and techniques that allow scientists to see, measure, and understand what’s happening during a fusion experiment. “Los Alamos has been a leader in building fusion diagnostic methods and interpreting data,” he says.

Over the years, Los Alamos researchers have designed systems that serve as the eyes and ears of current fusion experiments. “We built the fastest radiation detector in the world and are now studying gamma ray reaction history, neutron imaging, and how fusion fuel burns,” Meaney says.

In 2022, Meaney and his colleagues used Los Alamos–developed diagnostics to measure the first achievement of fusion ignition in a laboratory setting. Today, the Los Alamos team is applying those methods to answer further questions. This suite of specialized diagnostic techniques makes precise measurements of processes that take place incredibly quickly, such as neutron production.

“Once a fusion fuel capsule compresses, implodes, and ignites, we can study what physics phenomena dominate during the reaction,” Meaney says. Using a variety of diagnostic approaches, he can identify when sustained fusion reactions that release significant energy (fusion burn) start, how the fuel burns, how long the burn lasts, and what disrupts

it. “Since we can now reach ignition, we can test our fundamental understanding of the science taking place,” he explains. Meaney stresses the sophistication of the diagnostic systems he uses. “We are measuring phenomena that take place in 40 picoseconds,” he says, adding that a blink of an eye is about 10 billion times longer than 40 picoseconds. “These are screaming timescales,” he says.

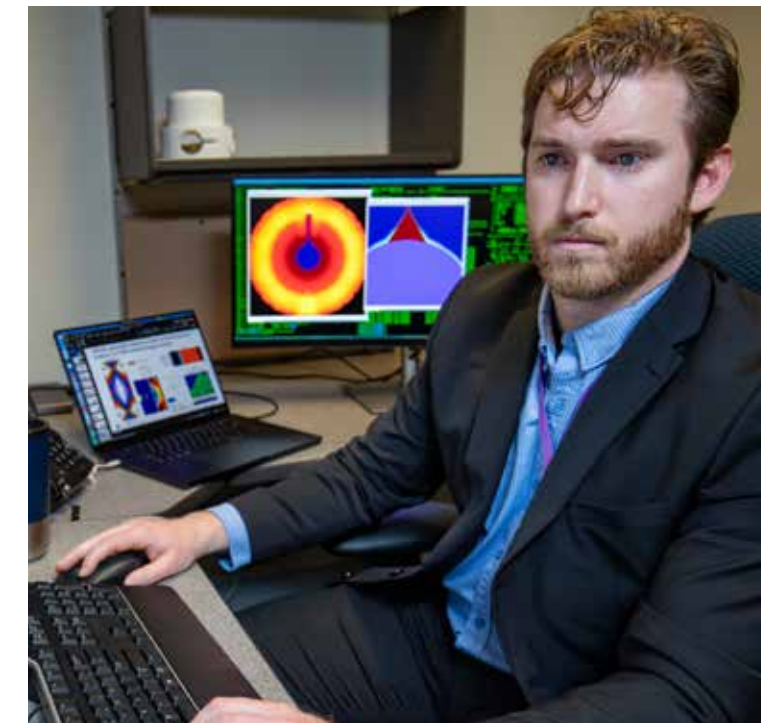

■ Physicist Ryan Lester reviews computer simulations of fusion experiments. These simulations use a Los Alamos–designed computer code to model experimental results.

Fusion approaches

Fusion occurs naturally in outer space—it's the process that powers the Sun and stars. Here on Earth, the United States national security laboratories (Los Alamos, Lawrence Livermore, and Sandia) focus on three principal fusion approaches: inertial confinement, magnetic confinement, and pulsed power.

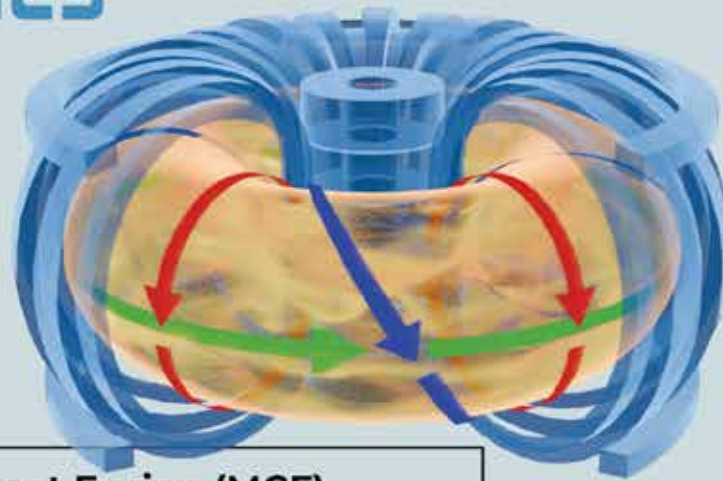

♦ ITER

Magnetic Confinement Fusion (MCF)

A fusion approach that uses strong magnetic fields to confine fusion fuel in the form of plasma—an electrically conductive, ionized gas—for extended durations. Devices such as tokamaks and stellarators operate this way.



Inertial Confinement Fusion (ICF)

A fusion approach that uses high-energy lasers, accelerated ion beams, or pulsed-power-generated radiation to rapidly focus energy on a tiny fuel capsule, compressing and heating it to extreme densities and temperatures. Facilities such as the National Ignition Facility and the Omega Laser Facility use ICF.



♦ NIF

Pulsed Power-Driven Fusion

A fusion approach that uses pulsed-power systems to generate ultra-high electrical currents over extremely short timescales, producing intense magnetic fields, radiation pulses, and dynamic compression. Facilities such as Sandia's Z machine use pulsed power to drive Z-pinch implosions—where current-generated magnetic fields compress plasma inward—and magneto-inertial fusion (MagLIF) experiments, which compress pre-magnetized fuel, to achieve fusion conditions.



♦ Z Machine

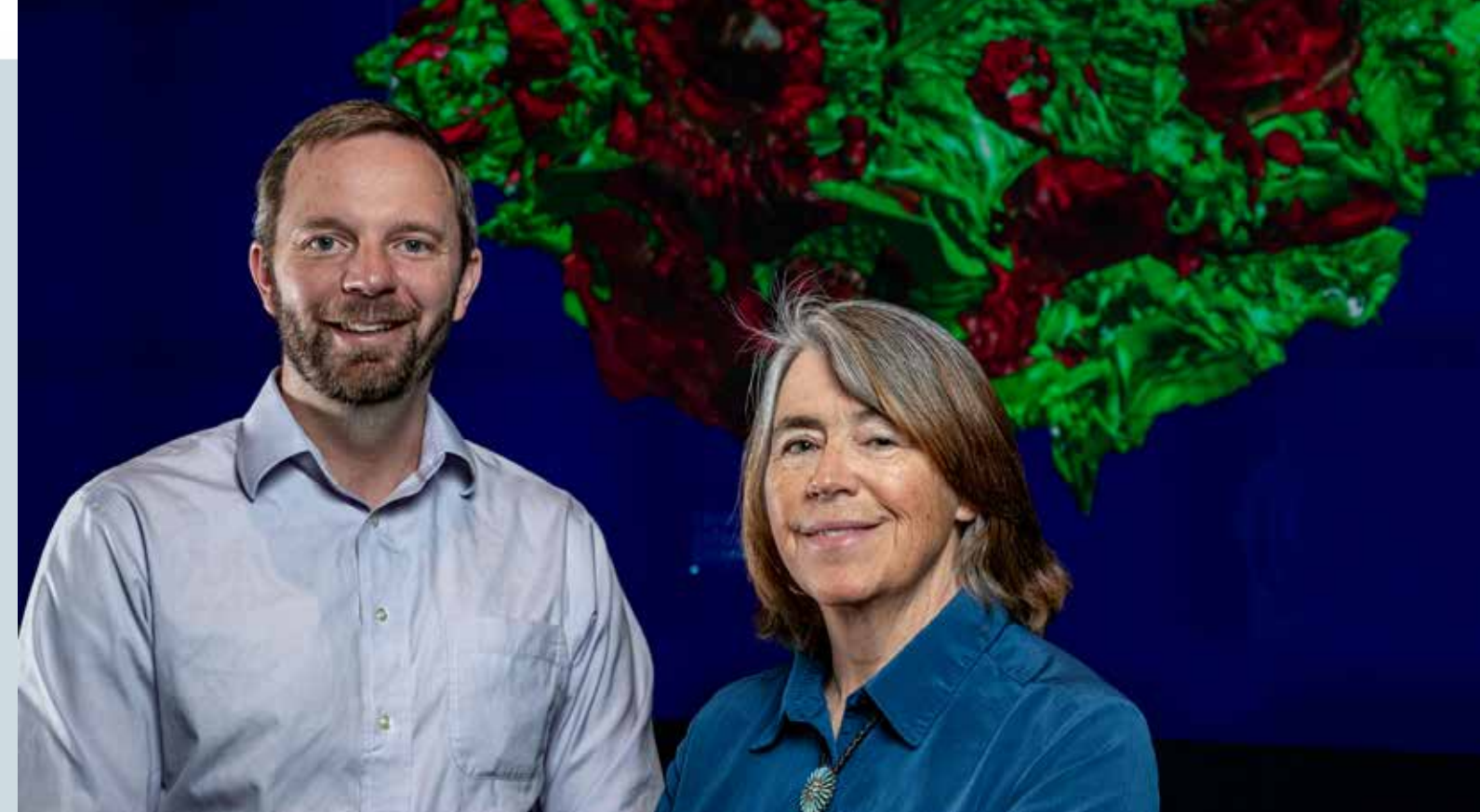
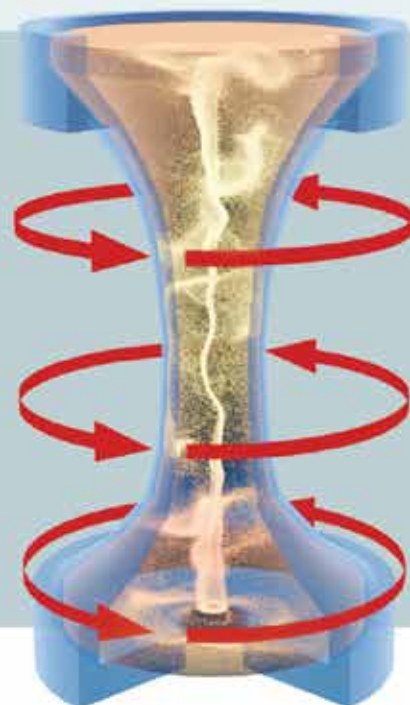

■ Smidt and Satsangi co-direct the Lab's inertial confinement fusion program, which provides essential capabilities and supporting knowledge required for ongoing design, assessment, and certification of the nuclear weapons stockpile.

Opening a window

Meaney's measurements provide data that Los Alamos scientists feed into computer codes to produce computational simulations of fusion processes. One such code is the Laboratory's state-of-the-art hydrodynamics computer code, xRAGE (Radiation Adaptive Grid Eulerian). This code allows scientists to make 3D simulations of what happens when a fusion fuel capsule compresses and implodes.

Los Alamos physicist Brian Haines, who made significant contributions to the development of xRAGE, notes the important role this code plays in fusion research. "The xRAGE code is one of the most advanced fusion modeling tools and has demonstrated unprecedented successes at predicting the outcome of fusion experiments," Haines says, adding that one of the Lab's major contributions to fusion research is providing leadership in computational modeling.

Recently, Los Alamos scientists used xRAGE to help design a new fusion ignition platform that produces an extreme x-ray output. The first application of this new platform took place in the summer of 2025 at NIF.

In a standard NIF fusion experiment, lasers are fired into a gold-coated cylinder called a hohlraum, which is just a few millimeters long and wide. The hohlraum holds a tiny capsule of fusion fuel. When NIF's lasers hit the inner walls of the hohlraum, they create a uniform bath of x-rays that drives the symmetrical implosion of the inner capsule, resulting in fusion ignition.

For this new platform, Los Alamos scientists designed a hohlraum with windows—openings—that allow the higher energy x-rays to escape. They named the new approach THOR: Thinned Hohlräum Optimization for Radflow. The goal is to use those escaping x-rays to bombard test materials to study radiation flow and absorption under extreme temperatures, pressures, and densities.

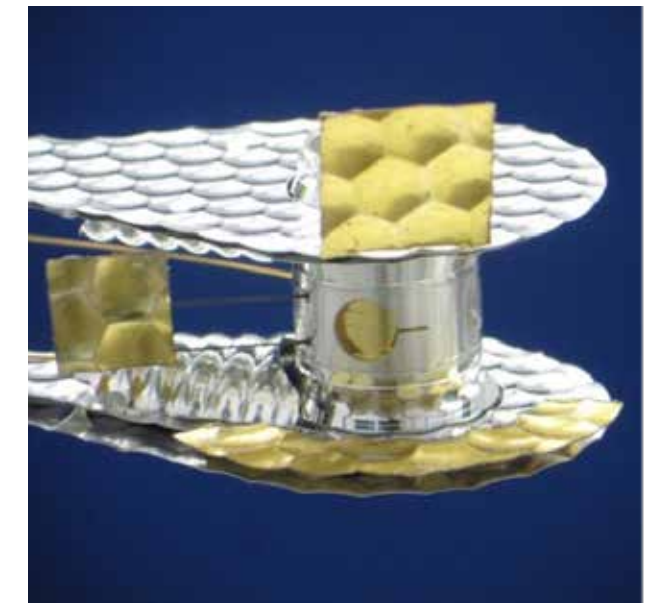

■ The gold THOR diagnostic windows allow x-ray flux to escape while withstanding the extreme preheat and shock environments present during ignition.

Lester says some of his colleagues thought ignition would be impossible to achieve with the added windows, but THOR proved them wrong. “It worked the first time—precisely matching our simulations,” he says. “Being able to reach ignition with the THOR platform allows us to study how radiation flows and evolves through the THOR windows,” Lester adds, noting that the platform has national security applications. “The platform also offers a way to learn how stars work, how radiation moves in materials, and lets scientists explore stellar opacities.”

Meaney, meanwhile, says he is looking forward to combining the Lab’s diagnostic techniques with the THOR platform. “THOR is using ignition to access states of matter that we haven’t been able to reach before,” he says. “It will help us learn about astrophysics, materials science, and many other areas. I’m excited!”

Lester says his goal now is to modify the windows to allow even more radiation to exit the hohlraum, paving the way for more focused, repeatable physics experiments. Some of Lester’s colleagues are still skeptical, but Lester is determined to prove them wrong. “Los Alamos has a history of rising to hard challenges. Why not add another layer of doing the impossible?” he says with a laugh.

■ Physicists Ryan Lester and Brian Haines examine a photo of the THOR target. Haines played an instrumental role in building the computer code used to design the successful THOR experiments.

With THOR, we’ve moved from figuring out how to achieve ignition to exploring the applications of ignition,” Lester says. “THOR is the next step.”

Targeting success

While THOR experiments strive to make the most of achieving ignition, Los Alamos scientists working on a different series of fusion experiments say ignition is not entirely necessary for their success. During these experiments, the NIF lasers shoot energy into a double-shell target, which is designed and built at Los Alamos. As in other NIF experiments, these targets consist of a fuel capsule inside a hohlraum. The difference is

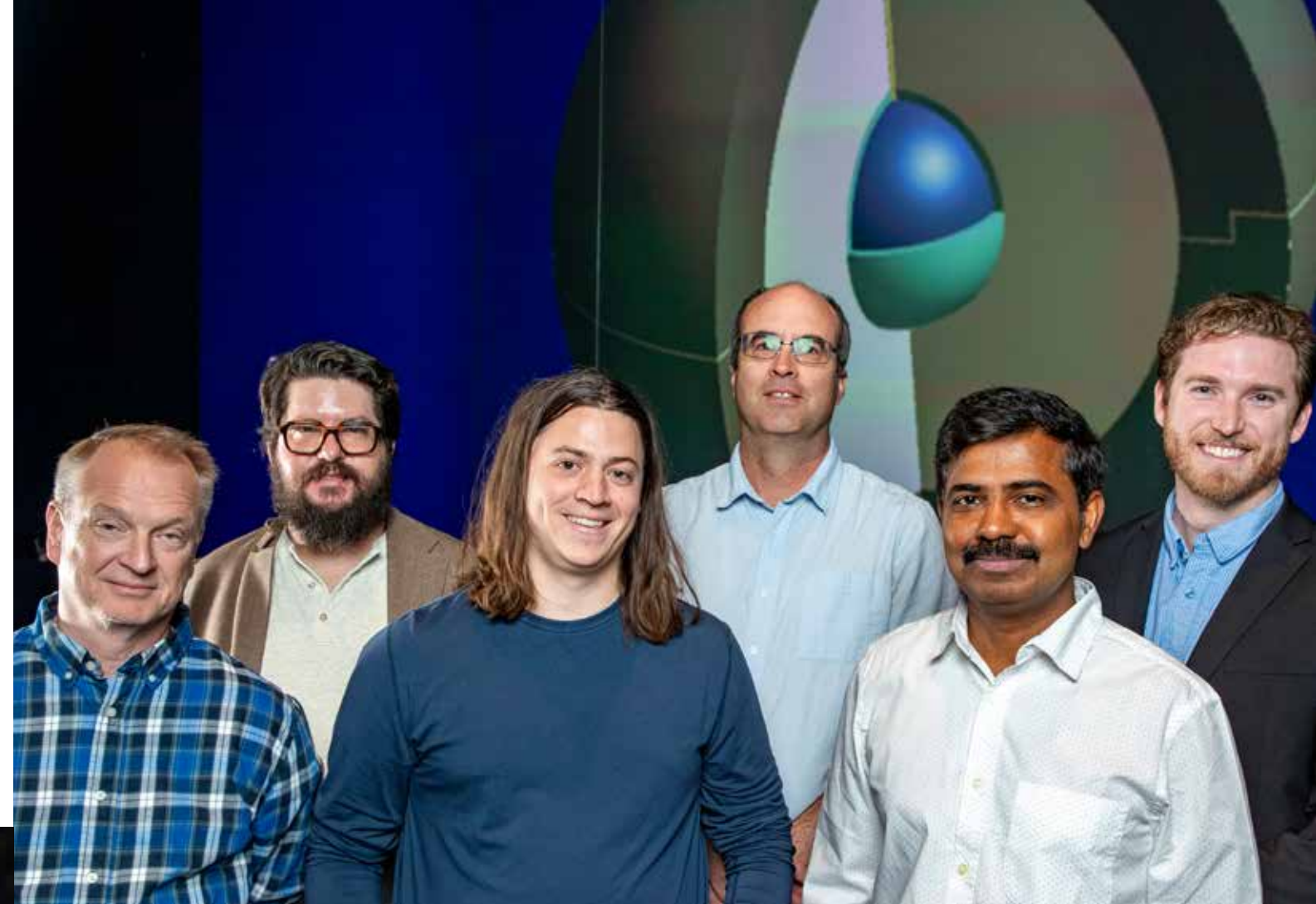
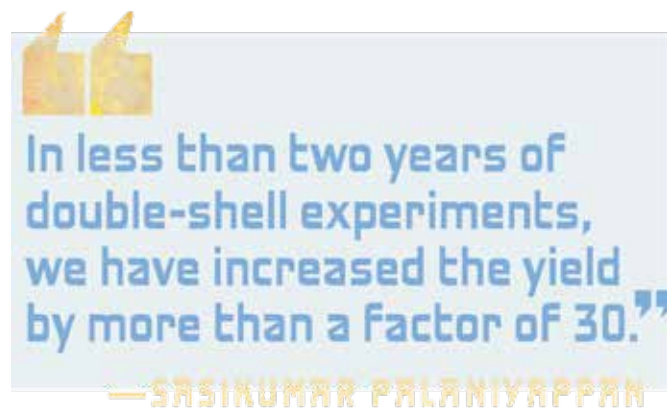

■ Some members of the double shell fusion team (from left): John Kline, Brian Haines, Ryan Scott, Eric Loomis, Sasikumar Palaniyappan, and Ryan Lester. The double-shell targets’ construction allows scientists to study unique aspects of the interactions of materials inside the target as it compresses and burns.

that double-shell targets have two nested layers: an outer shell made up of two hemispheres surrounding an inner shell filled with deuterium and tritium—the fusion fuel. Technicians place the target inside the hohlraum, which captures the laser energy and converts it into x-rays that compress and heat the target. The outer shell delivers energy inward, and the inner shell compresses the fuel, creating an implosion and generating neutron yield. This double-shell construction allows scientists to study unique aspects of the interactions of materials inside the target as it compresses and burns.

“In less than two years of double-shell experiments, we have increased the yield by more than a factor of 30,” says physicist Sasikumar Palaniyappan, noting this increase indicates that the experiment has created a successful fusion reaction. The double-shell design also enables what physicists call volume burn, in which the fuel can ignite and burn more uniformly throughout the capsule. Additionally, the double-shell targets allow scientists to analyze implosion dynamics and study how different shell materials interact with burning plasmas.

The higher neutron yields that scientists achieve with these experiments allow them to detect and measure radioactive isotopes created by fusion neutrons interacting with

surrounding material. This is known as radiochemistry, and it opens the door for scientists to study a condition called mix. Mix is an interaction between the shell and the fusion fuel that can decrease an experiment’s overall yield or successful volume burn—or even both.

When it comes to double shells, little things matter—extremely little things. Physicist Eric Loomis, who leads the double-shell project, says much of the team’s recent success comes down to the way the double-shell target is constructed. “Target fabrication makes or breaks a double shell,” he says, adding that refining the targets has increased the yield and produced better data. Using the xRAGE code, scientists and engineers identified ways to improve the target design.

For the engineers and technicians building these targets, success is a matter of microns—approximately 1.4 microns. Keep in mind that the average human hair is about 70 microns wide. Engineer Nikolaus Christiansen says he and his coworker Sam Stringfield have decreased the gap in the joint between the two hemispheres that make up the outer shell of the target from 1.4 microns to roughly 340 nanometers. How small

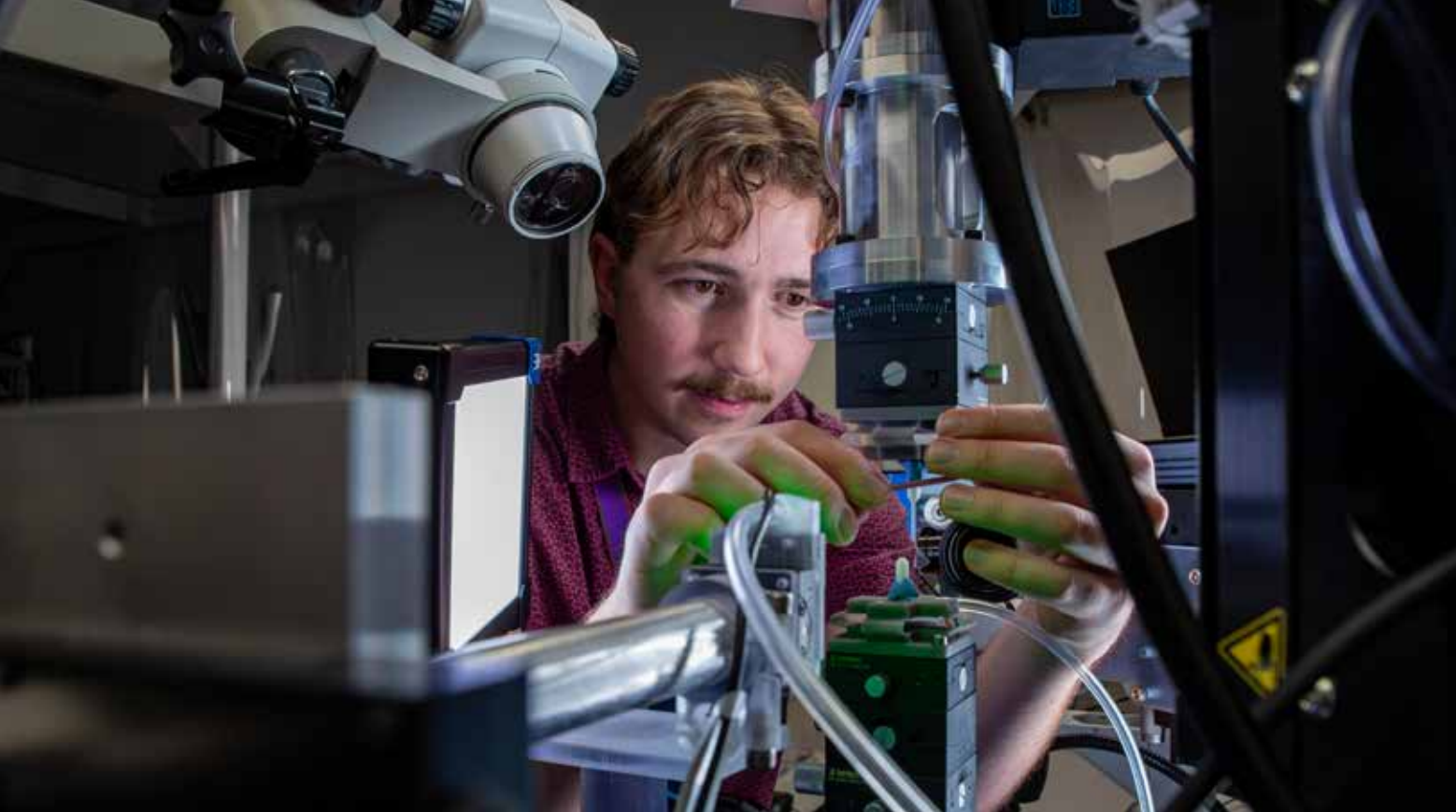

■ Using a sophisticated robot, Sam Stringfield assembles a double-shell target. Lab officials say recent improvements in target construction have led to higher energy yields and increased success.



■ Engineer Tana Morrow stands beside nuclear reaction history diagnostic device that provides physics data on the evolution of the burning fusion fuel. Los Alamos researchers developed the device, the Proton Trajectory Assay - Recoil Telescope (PAJARITO), to study thermonuclear burn experiments on the Z machine.

is a nanometer? DNA, the basic building block of life, is about 2 nanometers wide.

Christiansen says to achieve this miniscule gap, they build targets with the assistance of a sophisticated robot. They've also added a thin layer of gold at the outer shell joint. "The difference between 1 micron and 250 nanometers doesn't sound like much, but it is when it comes to our world," Christiansen says, joking that Stringfield has learned to hold his breath when building targets.

Stringfield laughs and points to a sign on the wall that reads, "Target Fabrication: where physicists' dreams become reality." He says, "It's satisfying to see the engineering improvements we are making have led to higher yield and better results."

Forging forward with fusion

As Los Alamos physicists move into the next phases of fusion research, they are grounded in the Laboratory's primary mission: nuclear deterrence. "The better we are at the science, the more informed we are about weapons applications, which can enable better decisions about future pathways," says physicist Ann Satsangi, who co-directs the Laboratory's inertial confinement fusion program. "We're building on decades of expertise in fusion research, and we have a significant role to play."

Physicist John Kline, who has spent most of his career working in fusion research at Los Alamos, agrees with Satsangi. "We are a fusion lab," Kline says. "It started here." ★

THE FUSION FANDOM

Researchers are drawn to the field for many reasons.

BY JILL GIBSON

The concept of creating fusion in the laboratory has captivated scientists for nearly a century. This quest to replicate the power of the stars ignites passion and persistence rarely paralleled in other fields. Over the decades, fusion research has played—and continues to play—a significant role in the careers of physicists and engineers at Los Alamos National Laboratory. *National Security Science* set out to explore what inspires some of the Lab's most focused fusion fans.



Some scientists say they were first drawn to the field because of fusion's potential for offering a transformational source of energy. Physicist David Meyerhofer says he began working in fusion research during his junior year in college. "I was a child of the 1970s energy crisis and decided to pursue a career in fusion as a future energy source."

Physicist Steve Batha followed a similar path. "My passion for fusion research began during the '70s when a lack of cheap energy began the awakening of America to our dependence on energy, especially energy created within our borders. My attention was drawn to plasma physics and fusion by my undergraduate research projects."



Although both Batha and Meyerhofer say their careers have pivoted to focus more on the national security applications of fusion research, the drive to create fusion energy still motivates many Los Alamos physicists and engineers. "The Laboratory has a broad range of capabilities that can be advantageous to the field of fusion energy," says chemical engineer Victoria Hypes-Mayfield. "I'm excited by the growth the Lab has seen in this area and hope to see more elevation of the efforts to bring fusion energy to the grid in future years."



The pursuit of fusion energy also inspires physicist Mike Lively. "Fusion research spans so many diverse fields, from plasma physics and mechanical engineering to materials science and radiation safety. It's great to work at the intersection of so many different fields and learn so many new things while driving toward a clean and sustainable energy future."



Lively notes that Los Alamos contributes to all areas of fusion research. "Some of these areas are obvious, like plasma physics and fluid dynamics work, but some of these areas might surprise you, like the nuclear reaction measurements and data that folks use for radiation transport calculations to make sure fusion power facilities will remain safe and operational," he says. "The Lab truly does it all!"

Hypes-Mayfield stresses the cross-disciplinary aspects of fusion research, saying, "I've always been really excited about the hugely collaborative nature of the field. The multitude of challenges facing fusion energy are closely linked, with

solutions in physics causing problems for engineering, and vice versa. This really drives home the need for close communication between all areas to create the solutions the world so desperately needs. None of the problems in fusion science can be solved in a vacuum, and a whole-system approach is needed."

That complexity inherent to fusion science attracts many researchers. Fusion is often described as a grand challenge problem that involves solving multiple scientific and engineering challenges simultaneously.

"Fusion research represents rich physics with lots of applications," physicist Ryan Scott says. "This is big science, and there's a lot to learn."

Postdoctoral researcher Damyn Chipman says all his work at Los Alamos is related to fusion. "The Lab is at the forefront of inertial confinement fusion research through novel ignition platforms, advanced diagnostics, and state-of-the-art computer simulation capabilities," he says. "It's a complex, multidisciplinary field that makes for some very interesting problems and rewarding challenges."



Speaking of challenges, other scientists point out that fusion research pushes their work to new levels. "I find fusion interesting because it combines so much disparate physics and really stresses our computational capabilities," says physicist Brian Haines, who helped develop the xRAGE computer code, a key fusion modeling tool.

Similarly, Derek Schmidt, the leader of the team that builds fusion targets, says, "The work has always been very challenging in an exciting way. Our requirements push us to have the world's highest precision machining and inspection capabilities to achieve the specifications that range from microns to nanometers."



"Indeed, fusion is a remarkable field," says physicist Radha Bahukutumbi. "To understand fusion, you can't just be a theorist. You must conduct simulations and experiments. You must go into the control room."



For Bahukutumbi and other fusion researchers at the Lab, the field is far more than a career: it's a calling. She says fusion demands resilience, persistence, and collaboration.

Finally, many Los Alamos scientists say they are drawn to the field due to their devotion to ensuring the safety, security, and reliability of the nation's nuclear deterrent. "Fusion research allows us to leverage unique capabilities for the nation and ensure global security," says researcher Robert Dwyer.

Physicist Ann Satsangi agrees. "At Los Alamos, fusion research is about embracing our national security mission."

She stresses the role that fusion science plays in designing, certifying, and assessing the nation's nuclear weapons, but also notes the many related applications for fusion research. "At Los Alamos National Laboratory, we are accustomed to using cutting-edge science to make a difference in the world." ★



FUSION

from then to now

More than a century of research supports today's fusion advances.

BY JAKE BARTMAN

The fusion of atomic nuclei has been part of the universe since it was formed some 13.8 billion years ago. A few minutes after the Big Bang, hydrogen isotopes deuterium and tritium fused to produce the helium-4 that is found throughout the universe today, releasing an enormous amount of energy in the process—as much as 10^{67} joules, according to Los Alamos National Laboratory physicist Mark Chadwick.

Scientists have been interested in fusion since British astronomer Arthur Eddington proposed, in 1920, that the process might explain the makeup of stars. No sooner had Eddington proposed this theory than he speculated that fusion could one day be harnessed by mankind: “If, indeed, the sub-atomic energy in the stars is being freely used to maintain their great furnaces, it seems to bring a little nearer to fulfillment our dream of controlling this latent power for the well-being of the human race—or for its suicide,” he said.

Only some three decades after Eddington's proposal, Los Alamos scientists would incorporate fusion into the design of the world's first thermonuclear weapons. Yet, the goal of using fusion to produce electrical power has proven elusive. More than 70 years after fusion was first used in weapons, no fusion reactor has demonstrated the mix of characteristics needed to make fusion power production both feasible and economical.

Today, at a time when private investment in fusion is reaching an all-time high and major projects such as the International Thermonuclear Experimental Reactor (ITER) are under construction, decades of advances—many of which have been made at or supported by research at Los Alamos—are helping bring the dream of fusion power closer than ever to reality.

Here, *National Security Science* traces fusion from its theoretical origins through its early use in weapon development and on to modern reactor research.

■ A worker is silhouetted against the reinforcing steel bars for the target building of Los Alamos National Laboratory's Antares laser facility. Antares was operated at Los Alamos in the early 1980s to study inertial confinement fusion, which involves compressing small capsules of hydrogen fuel to induce fusion.



Handwritten: $E = mc^2$

1905: Physicist Albert Einstein proposes the principle of mass-energy equivalence. Although French mathematician Henri Poincaré had previously described mass-energy equivalence in the context of electromagnetic energy, Einstein articulates the phenomenon as a general principle (part of his theory of special relativity), which he describes with the celebrated equation $E = mc^2$.

Albert Einstein at Switzerland's Federal Office for Intellectual Property in 1904, where he examined applications for patents. Einstein held the job for seven years, including during the period that he proposed his celebrated formula $E=mc^2$ (written above in Einstein's handwriting).



EARLY CONCEPTS AND THEORETICAL RESEARCH

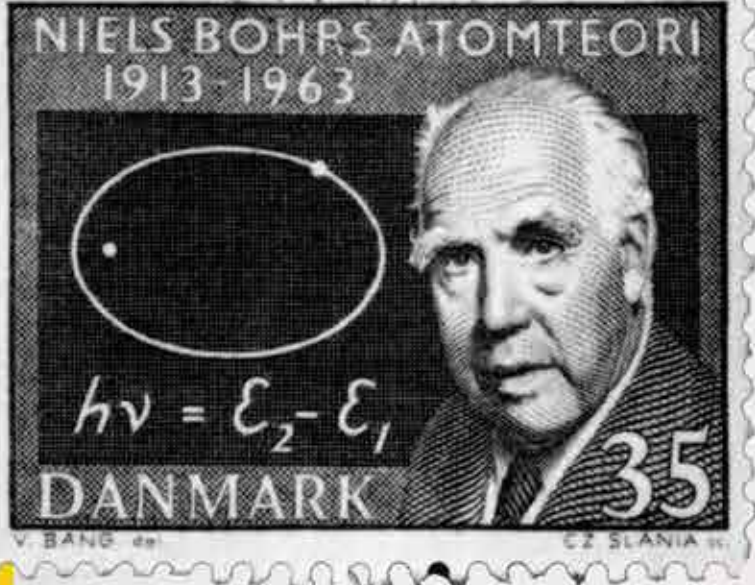

1911-1918: Physicist Niels Bohr develops and proposes his model of the atom, which builds on Ernest Rutherford's discovery of the atomic nucleus. The Bohr model, which supplants the earlier "plum pudding" model proposed by J. J. Thomson, envisions the atom as a dense nucleus orbited by electrons. Although this model of the atom will be supplanted by more sophisticated quantum-theoretical models in the 1920s, Bohr's work helps make possible Arthur Eddington's explanation of the Sun's mechanism (see opposite page).

Lorem ipsum

1919: Chemist Francis Aston builds a mass spectrograph that is a significant improvement over earlier designs, enabling the accurate measurement of the weight of individual atoms and their isotopes. Drawing on Einstein's theories, Aston's measurements suggest that when lightweight elements such as hydrogen combine into heavier elements such as helium, mass is lost as a release of energy.

British chemist Francis Aston's first mass spectrograph at the Cavendish Laboratory in 1919.

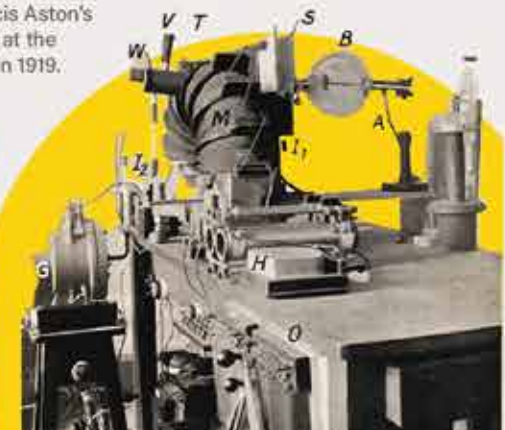

A stamp commemorating the 50th anniversary of Niels Bohr's development of his atomic theory.

1920: Astronomer Arthur Eddington suggests that stars such as the Sun are powered not by gravitational contraction—as theorists had speculated for the better part of eight decades—but by the fusion of atomic nuclei. Eddington summarizes his position as follows: "The atoms of all the elements are built of hydrogen atoms bound together, and presumably have at one time been formed from hydrogen; the interior of a star seems as likely a place as any for the evolution to have occurred; whenever it did occur a great amount of energy must have been set free; in a star a vast quantity of energy is being set free which is hitherto unaccounted for."

Arthur Eddington, who was the first to propose nuclear fusion as the mechanism that powers the stars.

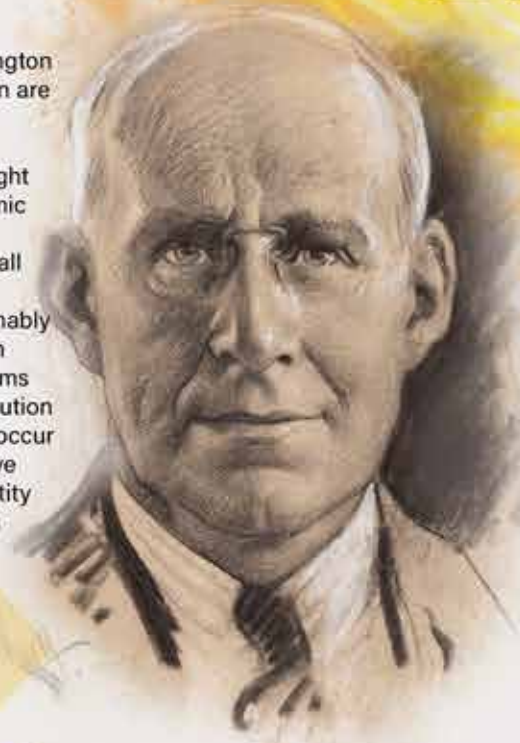

Not only is the universe stranger than we imagine—it is stranger than we can imagine.

—Arthur Eddington

1920

1930

1934: In a series of experiments at Ernest Rutherford's Cavendish Laboratory (at Cambridge University), physicist Mark Oliphant and other researchers bombard deuterium with accelerated deuterons, discovering helium-3 and tritium, which are created as products. Historians generally identify these experiments as the first-ever artificial fusion reactions.



Fritz Houtermans at the University of Göttingen in 1927.

1938: University of Michigan physicist Arthur Ruhligh publishes a paper in the *Physical Review* that includes the first observation of deuterium-tritium fusion reactions and remarks about the efficacy of these reactions. The paper receives little attention, but it is read by physicist Emil Konopinski, who later brings its concepts to key nuclear weapon development discussions during the Manhattan Project—the World War II-era effort to build the first nuclear weapons. (In 2024, scientists from Los Alamos and Duke University repeated Ruhligh's pioneering experiment with advanced detectors, finding that the observed deuterium-tritium fusion rates agreed with calculations in modern simulation codes.)

1940

1938-39: Physicist Hans Bethe publishes a series of papers explaining how hydrogen turns into helium inside stars via a process called the proton-proton chain for stars whose mass is similar to or less than that of the Sun or the carbon-nitrogen-oxygen chain for hotter, more massive stars. This research provides an important theoretical basis for future advances—including at Los Alamos—and increases scientists' confidence that controlled, sustained fusion can be achieved on Earth. In 1967, Bethe will be awarded the Nobel Prize in Physics in recognition of this work.

Hans Bethe being interviewed in the 1930s. Bethe's research would eventually earn him the Nobel Prize in Physics.

1929: Physicists Robert Atkinson and Fritz Houtermans build on the 1928 quantum tunneling work of physicist George Gamow to calculate the probability of proton-proton and light-nuclei fusion reactions inside stars. This work provides a quantitative theoretical description of the mechanism that Eddington proposed and constitutes the first calculation of the rate of fusion in stars, providing a mechanism by which fusion could conceivably occur even outside stars—perhaps even on Earth.

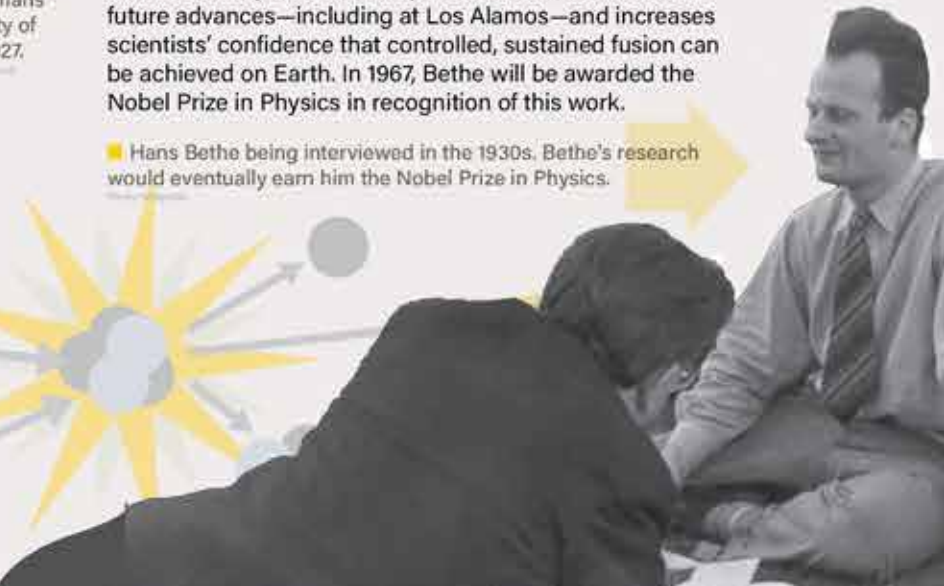



Le Conte Hall at the University of California, Berkeley (today's Physics North building), where J. Robert Oppenheimer's office was at the time of the 1942 nuclear weapon conference.

A list of lectures delivered at Los Alamos in the 1940s.



1942: At the University of California, Berkeley, physicist J. Robert Oppenheimer brings together a group of elite scientists (including Hans Bethe, John Van Vleck, Edward Teller, Felix Bloch, Richard Tolman, and Emil Konopinski) to study the feasibility of developing a nuclear weapon. Although the discussion centers on designs that would rely on fission—that is, the splitting, rather than fusing, of atomic nuclei—physicist Teller draws on Bethe's work to further propose developing a "super bomb" that harnesses fission to drive a fusion reaction. Bethe is skeptical of this proposal's feasibility, however.

1946: During a historic conference at Los Alamos, Teller presents the results of his wartime fusion research. Laboratory scientists agree that deuterium-deuterium fusion is the most promising path forward (in part because tritium is thought too difficult to attain in quantity). However, the technical barriers to designing a fusion weapon remain high, and the limited computational techniques of the time mean that key design questions are unanswered. Going forward, Los Alamos' thermonuclear program will focus on limited laboratory experiments, expanded theoretical studies, and research into the possible uses of tritium in a weapon.

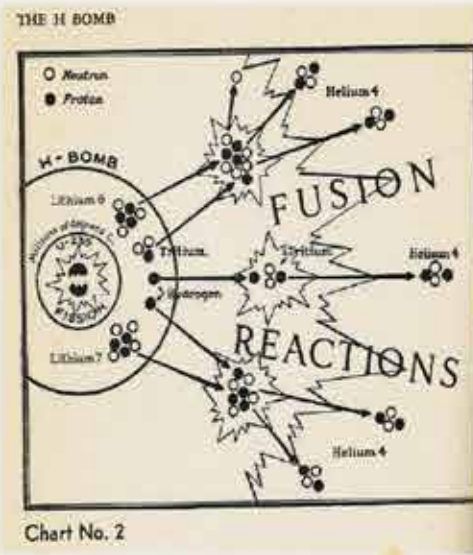
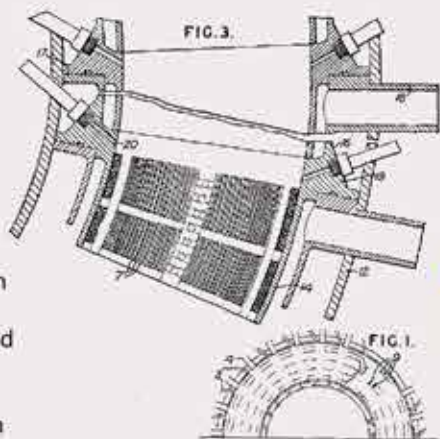

Chart No. 2



E.O. Lawrence (left) and Edward Teller (right) were instrumental in founding what would become Lawrence Livermore National Laboratory, one of the United States' two nuclear weapon design laboratories.



An illustration from George Fielding Eliot's 1950 book *The H Bomb*, demonstrating how a fusion weapon might work.

A drawing from George Paget Thomson and Moses Blackman's 1946 fusion device patent application.

Report written by:
E. Teller
S. Ulam

1950-51: Mathematician Stanislaw Ulam proposes an idea that Teller greatly improves upon to help make the design of a thermonuclear weapon possible.

LOS ALAMOS AND EARLY REACTOR IDEAS

1943-44: Teller arrives at Los Alamos—the center of the Manhattan Project—in spring 1943. Following the Berkeley study's conclusions, the Manhattan Project focuses on fission-weapon development. However, despite making important contributions to the fission program, Teller becomes preoccupied by calculations related to his "super bomb" concept. In mid-1944, Oppenheimer appoints Teller the leader of a new group that will focus exclusively on fusion research.



Edward Teller's Manhattan Project badge.

THEORETICAL DIVISION

- Bethe
- Teller
- Serber
- Weisskopf
- Bloch

A Manhattan Project Theoretical Division organization chart (Bethe was the division's leader).

Egon Bretscher (left foreground) and Robert Serber (right foreground) at a 1946 conference in Los Alamos, where researchers gathered to discuss the future of nuclear physics.

1946: The first patent of a fusion reactor is filed. British physicists George Paget Thomson and Moses Blackman propose a toroidal solenoid device that would confine a deuterium plasma and rely on the so-called "pinch" concept, with a strong current run through the plasma to produce self-pinching magnetic forces and confine the plasma. Thomson and Blackman are unable to secure funding to build their reactor, although it is now known that the design would have been unworkable regardless.

1947: In Cambridge, Manhattan Project veteran James L. Tuck helps physicist George Paget Thomson build a prototype pinch reactor, which uses magnets to pinch a plasma and confine it. In 1950, Tuck will return to Los Alamos and continue to conduct fusion research.

1945: At Los Alamos, British physicist Egon Bretscher measures the deuterium-tritium fusion cross section at relatively low energies, identifying a strong "resonance" that shows deuterium-tritium fusion to be much more probable at weapon-relevant energies than deuterium-deuterium fusion. This work helps enable the later use of the deuterium-tritium reaction in nuclear weapon design, although tritium is too expensive and difficult to produce at the time to be incorporated at scale into weapons. (Decades later, Los Alamos physicist Mark Chadwick will name the phenomenon of deuterium-tritium resonance the "Bretscher state" in Bretscher's honor.)

1950: The term "fusion" begins to appear in scientific publications as a description of the process that is the opposite of fission.

1950



A 1987 stamp commemorating Russia's role in developing the tokamak.

1950: In January, in response to the Soviet Union's first successful detonation of a fission device, President Harry Truman directs the Atomic Energy Commission to prioritize and accelerate its thermonuclear weapon research and development. The Laboratory adopts a six-day work week to achieve this goal. However, in October-November, calculations on the ENIAC (Electronic Numerical Integrator and Computer) machine suggest that Teller's proposed "classical Super" design won't work.

1950: Soviet physicists Andrei Sakharov and Igor Tamm propose the tokamak concept, which involves confining a plasma inside a toroidal (donut-shaped) device. The first tokamak isn't constructed until the late 1950s.

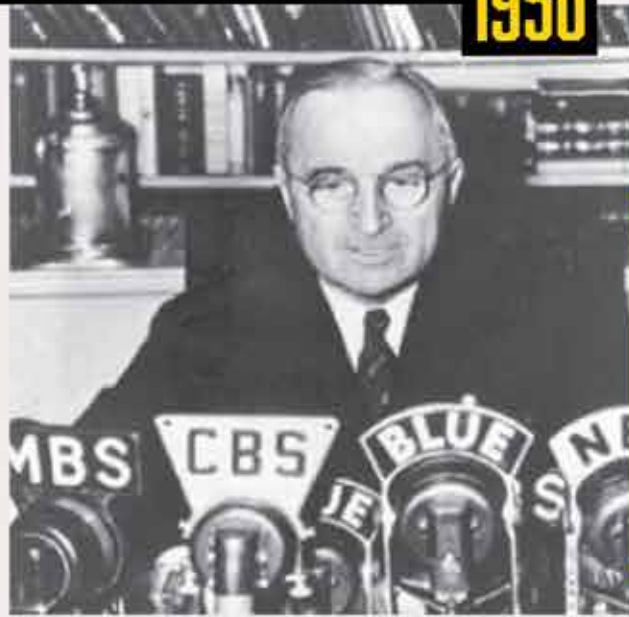

On January 31, 1950, President Harry Truman announced the U.S. plan to develop a hydrogen bomb.

"I have directed the Atomic Energy Commission to continue its work on all forms of atomic weapons, including the so-called hydrogen or superbomb."

—President Harry Truman



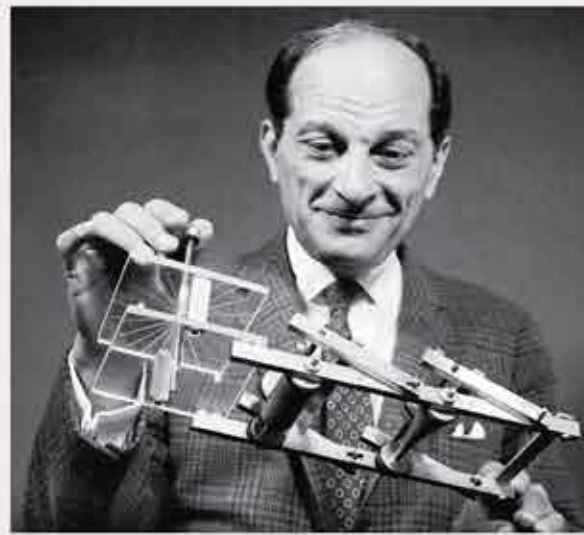

Stanislaw Ulam holds the Fermiac, an analog computer invented by physicist Enrico Fermi to study neutron transport.

“The goal is the controlled release of the energy of the fusion of the lightest nuclei. If this can be done, it will provide a source of energy which is virtually inexhaustible.”

—Lyman Spitzer

1951: On May 8, the United States conducts an experiment that marks the first instance of human-created “fusion burn,” or a self-sustaining series of fusion reactions inside a hot, dense region of fuel.

1951: On May 25, a Los Alamos experiment evaluates the “boosting” principle, which involves using a small quantity of fusion fuel to generate neutrons that substantially boost the rate of a fission reaction. The experiment is a major breakthrough for nuclear weapon design.



Lyman Spitzer with his Model A stellarator.

1953: At Princeton University, physicist Lyman Spitzer builds the first-ever stellarator, which he calls the Model A. Stellarators become the leading fusion reactor design in the United States—a status that they will retain for the better part of two decades until tokamaks prove more effective.

1954: Los Alamos scientists conduct a thermonuclear experiment that uses, for the first time, “dry” (rather than liquid) fusion fuel.



1956: An airborne thermonuclear exercise is carried out by the United States.

FROM WEAPONS PHYSICS TO CONTROLLED FUSION

1952: The United States conducts the first demonstration of a true thermonuclear device, which is designed at Los Alamos based on the Teller-Ulam design.

Marshall Holloway (center) directed the thermonuclear experiment described above.

1952: The United States launches Project Sherwood—a classified effort at Princeton University, Los Alamos, and Lawrence Livermore National Laboratory to develop several different types of fusion reactors.

The cover of a 1965 Los Alamos report on Project Sherwood, a formerly classified fusion reactor research effort.

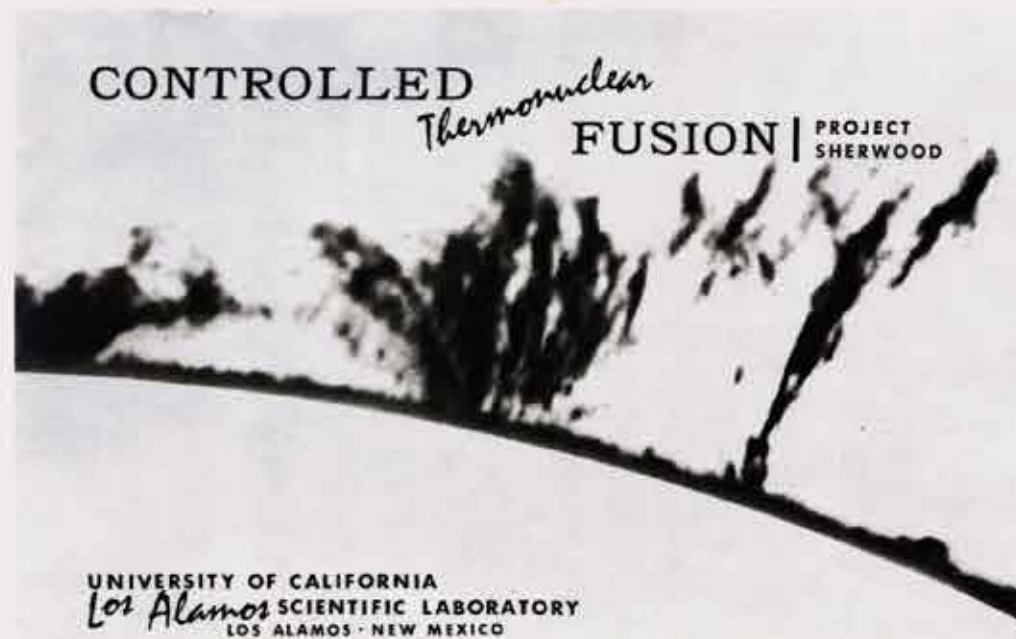

UNIVERSITY OF CALIFORNIA
Los Alamos SCIENTIFIC LABORATORY
LOS ALAMOS - NEW MEXICO

1952–53: At Los Alamos, as a part of Project Sherwood, James Tuck builds the Perhapsatron—a prototype Z-pinch reactor, which uses an electric current to magnetically “pinch” a plasma along its Z axis. The prototype is unsuccessful: Instabilities in the plasma consistently cause the plasma to disperse.

PERHAPSATRON S-4 STABILIZED TOROIDAL DISCHARGE

James Tuck built his Perhapsatron device at Los Alamos in 1953. The device was so named because Tuck thought that it would perhaps produce fusion (it didn't).

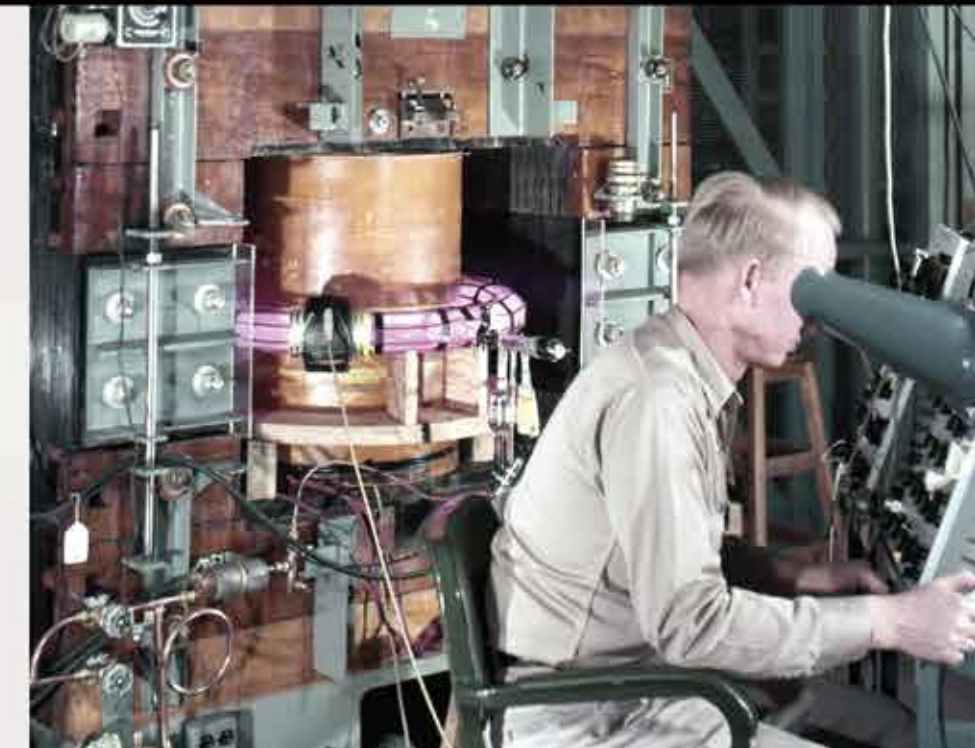

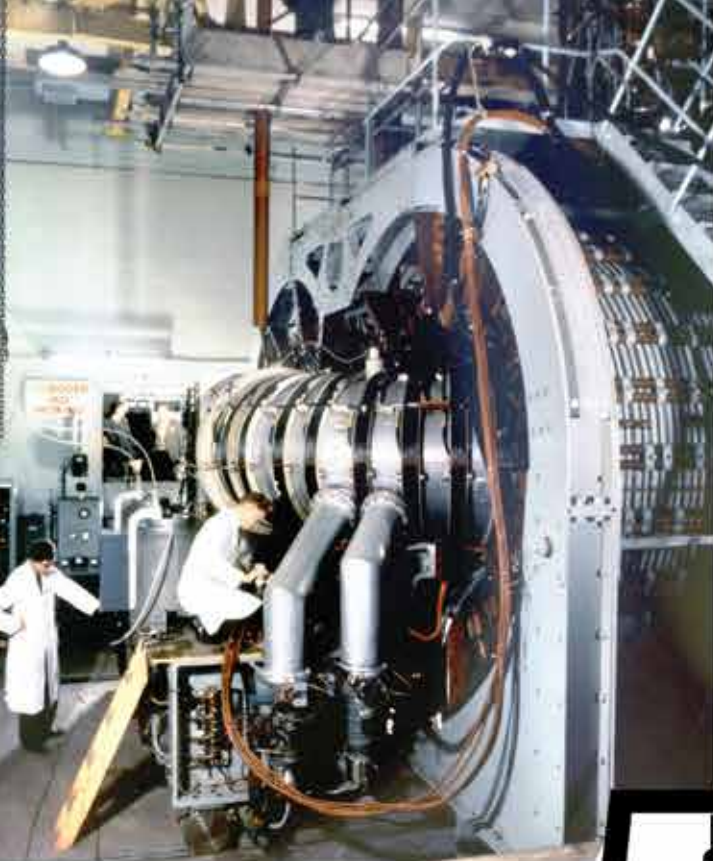

■ The ZETA machine, which researchers erroneously claimed was the first machine to achieve controlled thermonuclear fusion.

■ More than 6,000 delegates from around the world attended the second Atoms for Peace conference in Geneva, Switzerland, in September 1958.

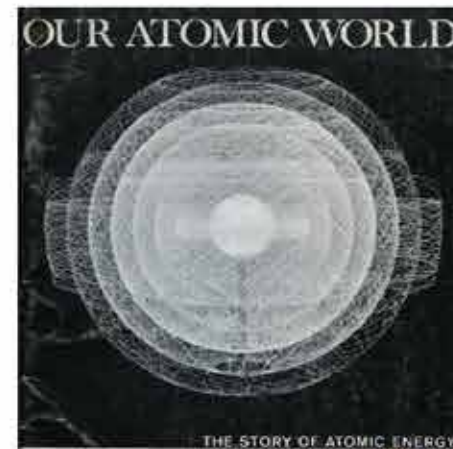

■ The Atomic Energy Commission published this pamphlet by former Manhattan Project physicist C. Jackson Craven in 1964.

■ Scylla IV (pictured in 1963) was the last in the Scylla series of theta-pinch fusion devices. The Scyllac device, constructed in the late '60s-early 1970s, attempted without success to significantly improve plasma confinement times.

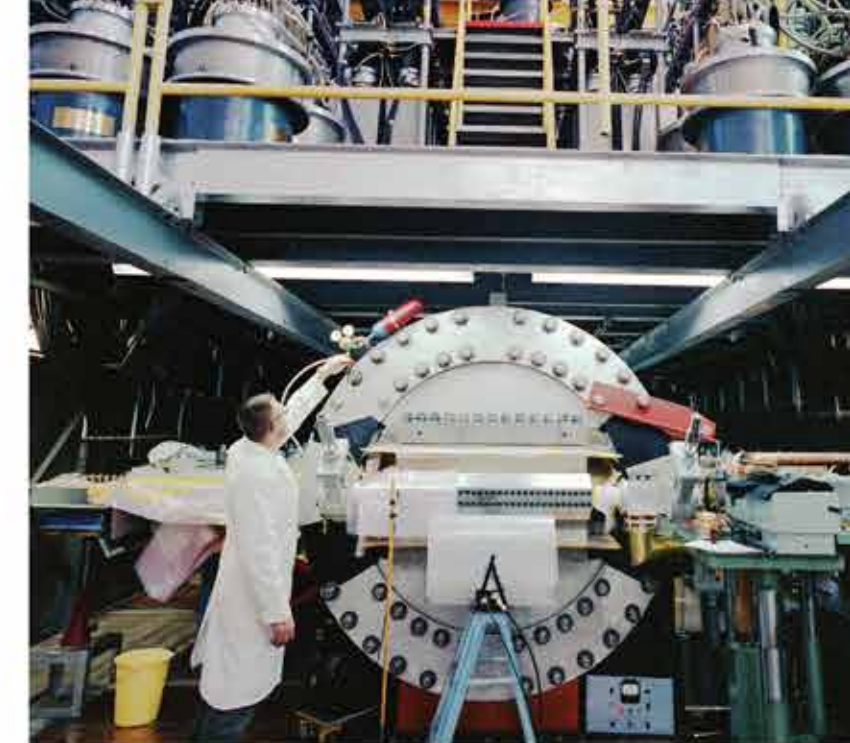

■ **1957:** The Zero Energy Thermonuclear Assembly, or ZETA, machine is completed in the United Kingdom. ZETA is the largest-ever pinch-type device, and in early 1958, researchers will claim that the device has successfully achieved fusion. A subsequent review will determine that this conclusion is erroneous and that instabilities in the plasma are responsible for the runaway neutrons that researchers interpret as evidence of fusion.

■ **1958:** Scientists at Los Alamos achieve controlled thermonuclear fusion reactions in a laboratory setting—a world first. The Laboratory's Scylla I machine employs a "theta pinch" approach that differs from the earlier Z pinch method by using a very short, intense pulse of current to pinch a plasma. Analysis of the neutrons, protons, and tritons produced during experiments on the machine suggest that its plasmas reach about 15 million degrees Celsius and that deuterium-deuterium fusion occurs. However, the machine is unable to sustain a fusion reaction for more than a few microseconds. Subsequent Scylla-type devices (Scyllas II-IV, 1959-63) at Los Alamos, which are funded by the Sherwood program, will attempt to expand confinement time.

■ In 1954, General Electric produced a pamphlet with this cover.

■ From left, Los Alamos researchers John Marshall, Josh Osher, and James Tuck in 1959 beside equipment used in Project Sherwood.

1960

■ Published by the Atomic Energy Commission in 1964, Samuel Glasstone's 48-page book *Controlled Nuclear Fusion* provided a concise overview of the state of fusion research to that point.



■ **1968:** In a major diplomatic achievement, five British scientists visit the Kurchatov Institute—home of the Soviet Union's nuclear weapon program—to evaluate the T-3 tokamak, which Soviet researchers claim produces far greater temperatures and plasma confinement times than had been achieved with other kinds of reactors. The British team's work validates the Soviet researchers' claims. In 1969, the British team publishes the results of its evaluation in *Nature*, and tokamaks quickly become the dominant magnetic-confinement reactor configuration in the international fusion community.

■ **1968:** Brookhaven National Laboratory leads the development and publication of the first Evaluated Nuclear Data File (ENDF), with Los Alamos and other U.S. national laboratories playing a supporting role. ENDF is a standardized evaluated nuclear data library used worldwide for modeling, simulation, and analyzing nuclear processes. Over subsequent decades, ENDF has continued to evolve, with Los Alamos contributing important benchmarks and fusion-related nuclear data to support today's deuterium-tritium fusion simulations.

■ **Mid-1960s:** Stellarators, pinch machines, and mirror machines continue to suffer from plasma instabilities and other shortcomings. Fusion research stalls.

■ Los Alamos physicist Fred Ribe in 1968.

■ An excerpt from a 1969 *Time* magazine article about Los Alamos' Scylla I device, which was the first machine to achieve controlled thermonuclear fusion.

The success cautiously announced by Dr. Tuck was achieved by Scylla, a cylindrical chamber about 30 inches long in which deuterium is squeezed by a sudden magnetic shock. The squeeze produces an egg-shaped fireball about 0.8 in. long containing five times 10^{16} (50 million billion) deuterium nuclei at a temperature of $13,000,000^{\circ}\text{C}$. It lasts about 0.9 millionth of a second, and spits out about 10 million neutrons. Dr. Tuck is sure that the Scylla neutrons came from genuine fusion of deuterium, but he points out that Scylla was

TIME, APRIL 4, 1960

TOKAMAKS AND ICF



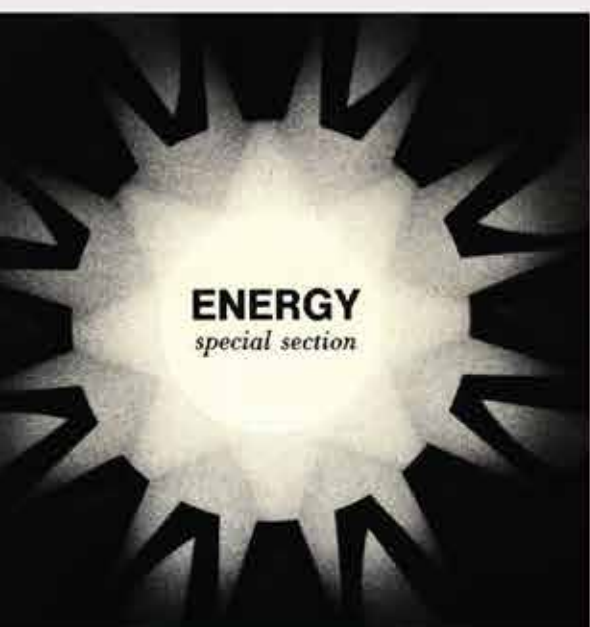

■ Livermore's Shiva laser operated from 1977 to 1981. Its target chamber, which was vacuum sealed and held deuterium-tritium targets as well as experimental diagnostics, is pictured here.

■ An image from a 1974 issue of Los Alamos' magazine *The Atom*.

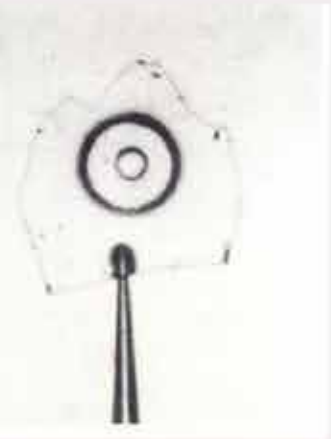

■ A fusion target from the first ICF experiments conducted at Livermore in 1974.

1970

- **1972:** Physicist John Nuckolls and other researchers at Livermore publish a paper in *Nature* that proposes using lasers to initiate fusion by compressing very small capsules of hydrogen fuel. The suggestion constitutes the basis of inertial confinement fusion (ICF) and is the culmination of more than a decade of classified research at Livermore. ICF becomes a central fusion research area.
- **1974:** KMS Fusion achieves a fusion reaction via ICF—the first-ever instance of laser-induced fusion. Months later, in December, Livermore's Janus laser will also be used to achieve fusion.

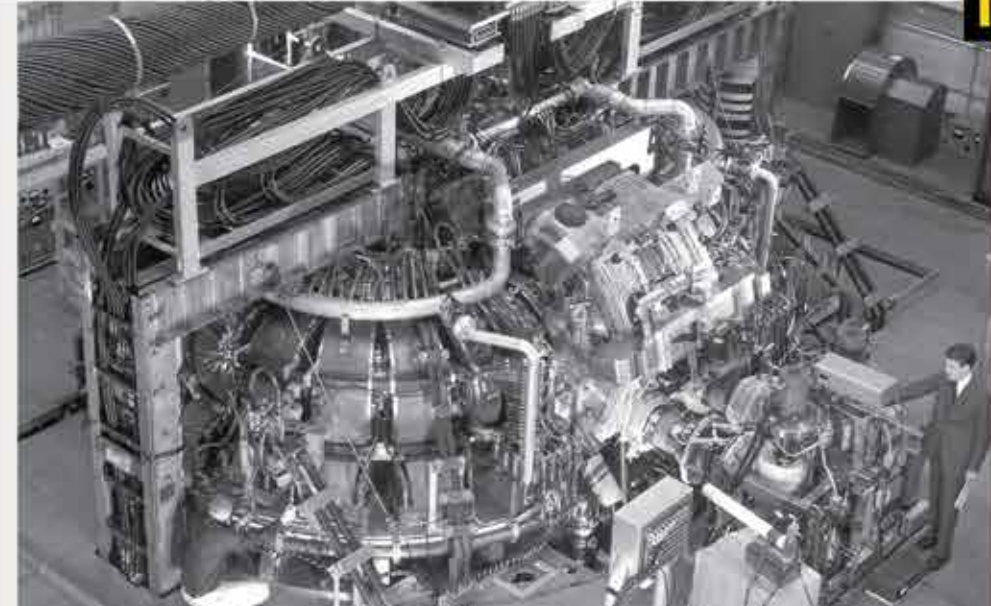

■ The Model C stellerator operated at Princeton Plasma Physics Laboratory from 1962 to 1969. The Model C built on the design of Princeton's earlier Model A and Model B stellerators.

1980

- **1970:** Princeton Plasma Physics Laboratory finishes converting its Model C stellerator into the Symmetric Tokamak, the first tokamak in the United States, underscoring the new American research focus on tokamaks. Results from the Symmetric Tokamak are on par with those of Russian tokamaks.

LASER FUSION: passing a milestone

■ Los Alamos' Antares laser is assembled.

- **Early 1980s:** Los Alamos begins operating the Antares carbon dioxide laser—an ICF facility that advances understanding of laser-driven implosions. Among other things, Antares' multi-beam, long-wavelength system demonstrates the limits of carbon dioxide lasers in ICF, helping guide the design of future ICF facilities toward shorter-wavelength lasers.
- **1980-1985:** The Tokamak Fusion Test Reactor, or TFTR (at Princeton University, 1982); Joint European Torus, or JET (United Kingdom, 1983;) and Japan Torus-60, or JT-60 (Japan, 1985) enter operation. All three large-scale tokamaks fail to achieve their most ambitious performance targets: None achieves scientific breakeven, or the point at which as much energy is produced by the reactor as is supplied to it. However, the reactors do attain significant advances in plasma confinement time and energy density, among other achievements.



- **1982:** At the Axially Symmetric Divertor Experiment (ASDEX) in Germany, researchers discover high-confinement mode, or H-mode—a phenomenon by which, above certain heating power levels, particle and energy confinement is approximately doubled. This discovery will prove important to future tokamak reactor designs, such as the International Thermonuclear Experimental Reactor, or ITER, which will take H-mode as its baseline operating regime when it begins experimental operations in the 2030s.
- **1982:** Los Alamos commissions the Tritium Systems Test Assembly, a large-scale experimental facility created to demonstrate the fuel cycle needed to sustain a working tokamak fusion reactor. Until its closure in 2001, the facility will provide valuable data about the fusion fuel cycle.

- **1984:** Livermore completes its Nova laser—the first of a series of ICF lasers intended to achieve fusion ignition (where the energy produced by the fusion reaction exceeds the energy supplied to the fuel). Nova will operate until 1999, and although it won't achieve ignition, it will provide key experimental data that supports development of NIF, where fusion ignition will be achieved.

■ Livermore's Nova laser was the world's most energetic laser system from 1984 to 1999, when it was dismantled to make way for the National Ignition Facility.



“The scientific laws, the physical laws, underlying the process are now sufficiently well known that even the skeptical, conservative scientists are willing to say yes, it's no longer a question of scientific feasibility.”

—Edwin E. Kintner, Department of Energy fusion program director

● A researcher with the target chamber of the Trident laser. Originally built by KMS Fusion in the late 1980s, the laser was moved to Los Alamos in the early 1990s.



1990

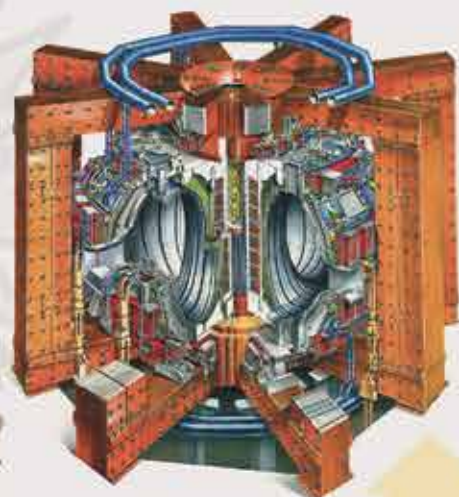

● Cutaway of the Joint European Torus (JET), which was located in Culham, United Kingdom.



● Sandia's Z machine generates extreme x-ray bursts and pressures to pursue fusion and other research.

INTERNATIONAL ADVANCES

● **1987:** Conceptual planning begins in Vienna for ITER. The project emerges as a symbol of international scientific diplomacy, with the United States, various European countries, the Soviet Union, and Japan leading the project. Over the next two decades, China, South Korea, and India will also become partners on ITER.

● **1986:** The DIII-D tokamak in San Diego, California, operated by General Atomics for the U.S. Department of Energy, becomes a cornerstone of U.S. fusion research. By pioneering advanced plasma control and confinement techniques, DIII-D provides key physics and operational insights for ITER and other prospective fusion power plants.

● The interior of the DIII-D tokamak, the largest operating tokamak in North America.



● **Late 1980s:** At Los Alamos, the Trident laser is commissioned to conduct ICF and high-energy-density physics research. Over the coming years, Trident will become a key laser-plasma capability that complements the Laboratory's historical magnetic-fusion research, supporting both fusion energy and weapons science. Trident will be decommissioned in 2017.

● **1989:** Chemists Martin Fleischmann and Stanley Pons announce the purported discovery of a fusion process that occurs at near room temperature. The process, which is labeled "cold fusion" by the press, quickly becomes a media phenomenon. However, attempts to validate Fleischmann and Pons's results are unsuccessful, and the discovery is soon discredited.

● **Late 1980s-1990s:** Using a Van de Graaf generator, Los Alamos physicists Charles Jarmie and Lowell S. Brown make the most-precise-ever measurements of deuterium-deuterium and deuterium-tritium reaction cross sections. These measurements become benchmark data for low-energy fusion reactions and are widely used around the world.

“Los Alamos has an extensive fusion research legacy.”

—John Kline

● **1991:** JET conducts experiments using a mix of equal parts deuterium and tritium fuel—a world first.

● **1993-1995:** At TFTR, researchers conduct an experimental campaign using a 50-50 mix of deuterium and tritium, proving that deuterium-tritium operation in a large tokamak reactor is feasible. In 1994, TFTR sets a then-world record for fusion reactor power output, producing a one-second burst of 10.7 million watts.

● **1995:** The 60-beam Omega Laser is commissioned at the University of Rochester's Laboratory for Laser Energetics in New York and becomes a key ICF testbed. National-laboratory teams—including Los Alamos—use Omega to study target designs, implosion stability, and fusion physics, providing data that inform later experiments at NIF.



● Inside the Omega laser's target facility at the moment of operation. Omega is a 60-beam system capable of delivering 30 kilojoules of energy to a target.

● **1996:** Sandia converts its Particle Beam Fusion Accelerator II into the Z Pulsed Power Facility, or Z machine. Similar to predecessor Z pinch machines built in the 1950s, the Z machine runs an electric current through a plasma to create magnetic fields that "pinch" the plasma. The Z machine is the world's most powerful pulsed-power facility, releasing up to 22 megajoules of energy in around 100 nanoseconds and producing extreme temperatures, pressures, and radiation similar to those found inside stars and nuclear explosions. This capability provides valuable data that supports fusion, high-energy-density physics, and national security research.

● **1997:** Japan's JT-60 achieves an extrapolated breakeven of 1.25, the current world record. Extrapolated breakeven differs from scientific breakeven in reflecting the expected performance of the machine if it were running on deuterium-tritium fuel (rather than on hydrogen or deuterium fuels, which are cheaper to work with and easier to handle; for this reason, they are used more often reactor research).

● **1997:** At Livermore, ground is broken on NIF. Comprising 192 lasers trained on a 2 millimeter target, the facility will become the first place in the world to achieve fusion ignition. The facility also conducts important research to ensure the safety, reliability, and effectiveness of U.S. nuclear weapons.

● NIF's target chamber during construction. Each of the plates pictured here is 11 centimeters thick.

● **1998:** Tri Alpha Energy launches in California, becoming one of the first of a new generation of private companies that seeks to develop a fusion power reactor.

● **1997:** JET sets a record for the closest approach to scientific breakeven (the point at which the energy put into heating a fusion fuel equals the energy produced by the fusion reaction within the plasma). Breakeven is represented as a fusion gain factor, or Q, of 1; JET achieves a Q of .67. For reactors that rely on magnetic confinement, this record still stands. This and other achievements at JET provide critical information for ITER's design.



For more than 60 years, there has been a worldwide quest to solve incredibly complex physics challenges and achieve controlled, peaceful fusion, which would transform our world's energy needs."

—Mark Chadwick, associate Laboratory director, Los Alamos

ITER agreement signatories in Paris, 2006.

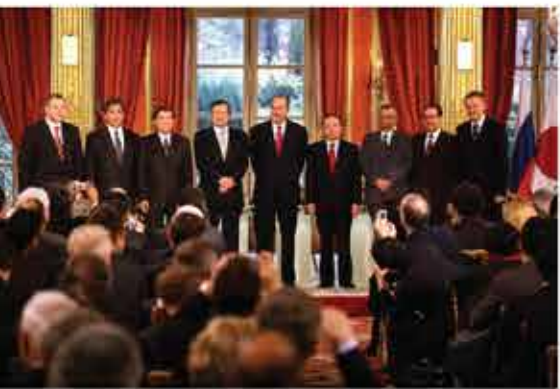

2001: NIF's main infrastructure is completed. Work begins on assembling and qualifying the facility's lasers.

2006: The ITER Agreement is signed by the European Union, China, India, Japan, Russia, South Korea, and the United States, clearing the way for reactor construction to begin at ITER's site outside Cadarache, France.

2008: South Korea's KSTAR (Korea Superconducting Tokamak Advanced Research) begins operation, demonstrating long-duration, high-temperature plasma control with superconducting magnets. Results achieved at KSTAR support ITER.

2009: NIF's 192 lasers are fired simultaneously for the first time. In June, full-scale experiments begin at the facility.

2010: The first concrete is poured as part of ITER's construction.

The first concrete is poured at ITER in 2010, inaugurating the facility's construction in earnest.

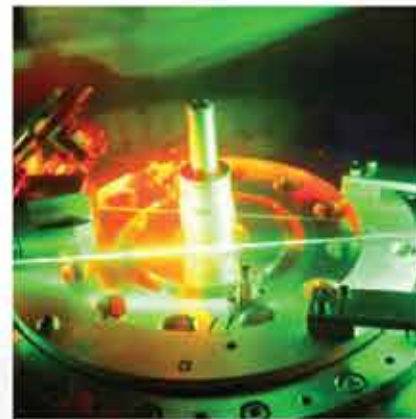

A z-pinch wire array target is prepared for a shot on Sandia's Z machine.

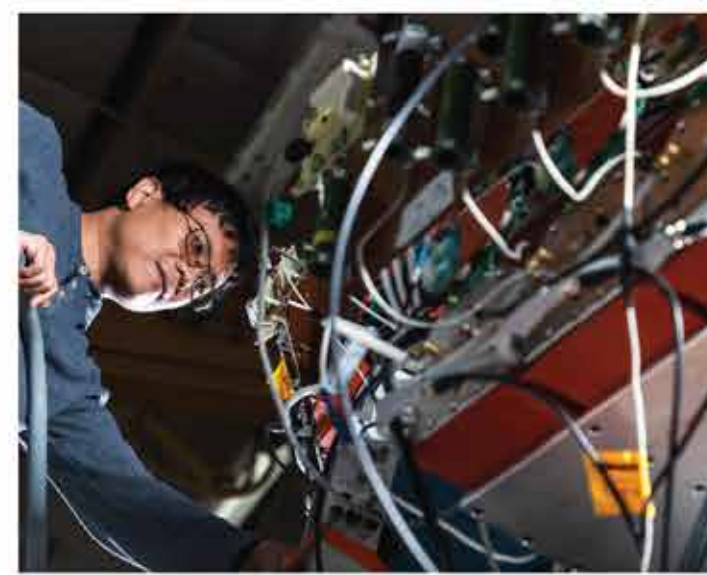

A researcher with Los Alamos' PLX, which blends magnetic and inertial confinement fusion approaches.

At Los Alamos' target fabrication facility, engineers create one-of-a-kind targets—smaller than a person's pinky nail—for NIF experiments.

2010: Los Alamos launches the Plasma Liner Experiment (PLX), which explores magneto-inertial fusion concepts that are a "hybrid" between magnetic confinement and ICF techniques. PLX is designed to use converging supersonic plasma jets to study compression relevant to future fusion reactor concepts.

2010s: Los Alamos establishes a dedicated program to design and fabricate double-shell ICF capsules for experiments at NIF. Double-shell targets consist of an outer shell that is driven into an inner shell by x-rays, compressing the deuterium-tritium gas inside the inner shell in a way that could achieve more stable and robust fuel compression. Today, ongoing double-shell experiments and modeling at NIF points toward the possible future use of these targets in shots that could produce fusion ignition.

2013-14: MagLIF experiments on Sandia's Z machine produce promising results. MagLIF, which stands for magnetized liner inertial fusion, is an ICF-like technique developed at Sandia that preheats hydrogen fuel inside a metal liner with a laser and then compresses the fuel with a powerful magnetic field. Using deuterium fuel, researchers produce a trillion fusion neutrons, suggesting that the MagLIF technique could be a viable path to achieving controlled fusion reactions.



ITER, NIF, AND PRIVATE INVESTMENT

2000

The support structures and clean enclosures for all 192 of NIF's beams were completed in 2003.

2003: Sandia's Z machine produces a fusion reaction for the first time, suggesting that Z pinch devices could be a way to achieve controlled thermonuclear fusion.



2000s: xRAGE (Radiation Adaptive Grid Eulerian), a Los Alamos radiation-hydrodynamics code, becomes a key tool for modeling ICF experiments. xRAGE plays a crucial role in understanding how radiation transport, shocks, and thermonuclear burn unfold in ICF capsules, helping predict how extreme conditions drive fusion implosions.

A simulation produced using Los Alamos' xRAGE code.

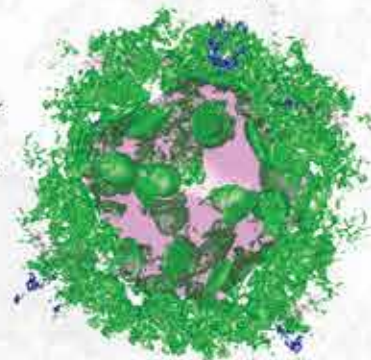

2010

Sandia's Z machine has produced promising MagLIF experimental results.



Inside NIF's target chamber.

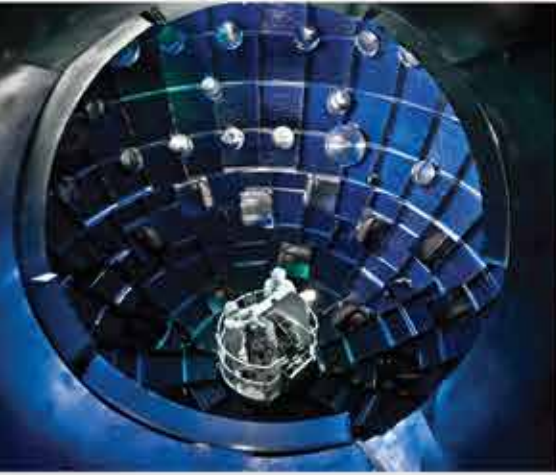

“The pursuit of fusion ignition in the laboratory is one of the most significant scientific challenges ever tackled by humanity. Achieving it is a triumph of science, engineering, and most of all, people.”

—Kim Budil, director, Lawrence Livermore National Laboratory



The THOR target, which was used in a successful NIF experiment in 2025, has important national security research applications.

NIF Director Gordon Brunton, right, shows Brandon Williams, administrator of the National Nuclear Security Administration, an ICF target in 2026.



2020

2022: At NIF, on December 5, fusion ignition is achieved, with 3.88 megajoules of energy produced out of the 2.05 megajoules delivered to the target. This achievement, which is hailed internationally as a breakthrough, will be repeated and surpassed several times at NIF in the coming years.

2025: At NIF, a Los Alamos team achieves fusion ignition using a novel hohlraum (which contains the fusion fuel) called THOR (Thinned Hohlraum Optimization for Radflow). THOR contains windows around its equator that allow high-energy x-rays to escape and be used for national security-related experiments, among other applications.

2015: In Greifswald, Germany, the Wendelstein 7-X stellarator is completed. The machine, which is the world's largest stellarator, is partially supported by an American consortium that includes Princeton University, Oak Ridge National Laboratory, and Los Alamos. In the intervening years, the stellarator has seen several upgrades and demonstrated steadily longer plasma confinement times, aiming eventually to achieve a total of up to 30 minutes of continuous plasma discharge and to show that stellarators are well suited to continuous operation.

The Wendelstein 7-X stellarator has produced promising results in recent years, reviving international interest in stellarators.

2020: ITER begins the assembly of its main tokamak components. The reactor is slated to begin experimental operations in 2034.

2015–2020: Private fusion companies such as Commonwealth Fusion Systems, General Fusion, Helion, Tokamak Energy, Zap Energy, and others raise increasingly large amounts of money to pursue the development of diverse fusion reactor concepts.

A fusion history workshop brought leaders from around the United States to Los Alamos in 2024.

2025: The WEST (Tungsten Environment in Steady-State Tokamak) reactor in France (formerly known as Tore Supra) sets the current world record for plasma confinement time in a tokamak, sustaining a 50-million-degree-Celsius plasma for 22 minutes and 17 seconds. This is an increase of approximately 25 percent over the previous record, which was set by China's Experimental Advanced Superconducting Tokamak (EAST). The achievements at WEST and EAST are important steps toward confining plasmas on timescales relevant to commercial fusion energy production.

2023: JET, which has been reconfigured to address questions relevant to ITER's design, attains the current world record for energy output from a magnetic-confinement fusion reactor. Using 0.2 milligrams of fuel, JET produces more than 69 megajoules of heat over 5 seconds, surpassing the facility's previous 2021 world record (69 megajoules of energy could power an average American household for approximately 15 hours). The results boost hopes for ITER's success.

ITER is expected to begin experimental operations in the mid-2030s.

TODAY

“At Los Alamos, we are actively engaged in all aspects of fusion research.”

—Charlie Nakhleh, deputy Laboratory director for Weapons, Los Alamos

Jill Gibson contributed to this timeline.



HAROLD

Los Alamos National Laboratory's third director remains a legend today.

BY JAKE BARTMAN

AGNEW

■ While supporting the Laboratory's early thermonuclear research, Agnew caught this barracuda.



“Harold was a kind of Forrester Gump of the new nuclear age—a participant in many of its most important events.”

—GLEN McDUFF

Anyone who knew Harold Agnew, Los Alamos National Laboratory’s third director, has more than one Agnew story to tell. Roger Meade, who was formerly an archivist and historian at the Laboratory and who came to know Agnew after the director left Los Alamos, says that the story of Agnew’s arrival at the Laboratory is his personal favorite.

Agnew first came to Los Alamos in 1943, not long after a secret laboratory was created in the New Mexico mountains as Project Y of the Manhattan Project (the wartime effort to build the world’s first nuclear weapons). At age 21, Agnew had already played a part in one historic endeavor, having worked under Enrico Fermi at the University of Chicago on the Chicago Pile-1 (CP-1) reactor, which achieved the world’s first controlled nuclear chain reaction and opened the door to the development of nuclear reactors and nuclear weapons alike.

According to Agnew, though, it wasn’t his role on Fermi’s team that led J. Robert Oppenheimer, the Manhattan Project’s leader, to recruit him to Los Alamos. Instead, it was Agnew’s wife, Beverly, who was really hired for the project. As a secretary, Beverly had supported the administrator of the CP-1 endeavor, and when Oppenheimer would visit Chicago, he’d often stop to talk with Beverly. Eventually, Oppenheimer asked Beverly to be his secretary at Los Alamos. Agnew, meanwhile, who had been forced by exposure to radiation to take time off from experimental work, came to the Laboratory in the spring of 1943 as part of a package deal.

“I showed up at Los Alamos, and it was a Sunday, and my wife hadn’t arrived yet,” Agnew told Time magazine. “And I ran into Oppie. And all he said was: ‘Where’s Beverly?’ Which crushed me. From that day, I knew exactly where I stood with that guy.”

In its irreverence, the story is vintage Agnew. But the anecdote also reflects an unusual aspect of Agnew’s life: his having played a part in many pivotal events in

20th-century nuclear history, including CP-1’s development, the Manhattan Project, the Hiroshima mission, early fusion demonstrations, and more. In the words of retired Laboratory researcher Glen McDuff, Agnew was a kind of “Forrester Gump of the new nuclear age—a participant in many of its most important events.”

“He was one of those fortunate individuals who was there almost from the beginning,” Meade says. “He knew everybody. He participated in so many things that it’s hard to believe.”

The story of Agnew’s arrival in Los Alamos also hints at his ambition—a characteristic that helps explain how he would work his way up and become, nearly three decades after his arrival in Los Alamos, the Laboratory’s third director, serving in that role from 1970 to 1979. Under Agnew, the Laboratory developed programs that expanded its research into areas with little or no direct connection to nuclear weapons, including energy, environmental and earth science, biology, and more. “The Laboratory entered the final stage of its evolution when Harold was director,” says Alan Carr, Los Alamos’ senior historian, who knew Agnew personally. “Under Harold, we transitioned from being a nuclear science laboratory to a truly multidisciplinary institution.”

At the same time, during Agnew’s directorship, the Cold War was underway. Agnew championed the development of many of the weapons that remain the basis of the United States’ nuclear stockpile, and he supported key innovations that made those weapons safer. He was a staunch believer in nuclear deterrence and a fierce opponent of any bureaucracy that he thought hindered the Laboratory’s work—an attitude that sometimes rankled decision-makers.

Asked in 2005 about his directorship, Agnew didn’t hesitate to identify what he considered his crowning achievement. “About three quarters of the U.S. nuclear arsenal was designed under my tutelage at Los Alamos,” he said. “That is my legacy.”

A “well-liked boy with an analytical mind”

Agnew was born in Denver, Colorado, in 1921, the only child of a stonemason and a homemaker. His father had graduated from Cooper Union, a college in New York City, and was a devoted tinkerer who “usually worked every night on some gadget,” Agnew said in a 1983 oral history. Agnew would attribute his interest in physics and chemistry partly to this habit of his father’s.

Having spent his formative years during the Great Depression, Agnew learned to be thrifty and to work hard. While still in high school, he had jobs as a stableboy, a janitor, and a lifeguard. Matriculating at the University of Denver, he was a star student, president of his senior class, and a member of the Beta Theta Pi fraternity and Phi Beta Kappa—a “well-liked boy with [an] analytical mind,” according to the university’s 1942 yearbook. While at the university, he met fellow student Beverly Jackson, whom he married in May 1942, a month before he received his degree in chemistry. The couple would remain together until her death nearly seven decades later.

After Japan attacked Pearl Harbor in December 1941, the United States joined the Second World War. Originally intent on enlisting with Beverly in the Army Air Corps, Agnew was instead recruited by a professor to take part in a secret project at the University of Chicago. There, he was introduced to scientists in the university’s Metallurgical Laboratory, where researchers were studying uranium and plutonium as part of the secretive Manhattan Project. Just a few years before, in 1938, a team of chemists and physicists in Germany had

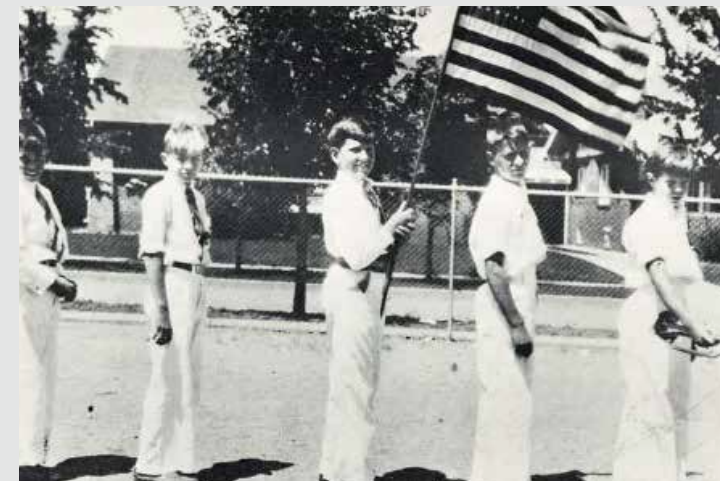

■ Agnew (at center with flag) was known throughout his life for his patriotism and his belief in nuclear deterrence.

discovered nuclear fission—the process by which an atom’s nucleus is split, releasing energy. Rumors that Germany was attempting to develop a weapon that harnessed this process helped drive the creation of the Manhattan Project, whose leaders aimed to beat the Nazis in the race to develop the world’s first nuclear bomb.

Agnew soon found himself working under Enrico Fermi, an Italian physicist and Nobel laureate, as Fermi developed a prototype nuclear reactor—a key step toward creating a nuclear weapon. Soon, Fermi’s team began assembling the graphite reactor, which came to be known as CP-1, on a squash court beneath the bleachers of the University of Chicago’s football field. “I personally did not like working on the pile,”

■ The Agnews’ Manhattan Project badge photos.



Agnew recalled. “It was very dirty work. Dirty in the sense of [handling] the graphite. Like being a coal miner.”

According to Agnew, he had little awareness of CP-1’s significance until well after the reactor went critical on December 2, 1942, thinking the project “just another one of Fermi’s experiments.” He recalled, “At this point, I still didn’t know what the hell this was all about. Everything was very secret.”

At Project Y and over Japan

Agnew acquired a more complete understanding of the work he was contributing to when he came to Los Alamos in the spring of 1943. He spent the next two years at the Laboratory conducting experiments with a Cockcroft-Walton generator, bombarding disks of material—platinum and gold followed by nuclear weapon-relevant materials such as uranium and tungsten—to determine the materials’ scattering cross sections (that is, the materials’ propensity to capture neutrons). This research supported the design of the weapons that would be detonated over Japan in August 1945, helping to bring World War II to an end.

During the Manhattan Project, Agnew became involved in another research area that would make him a witness to the Hiroshima bombing. At Los Alamos, Agnew began working with physicist and future Nobel laureate Luis Alvarez, who was adapting acoustic sensors into gauges that could be dropped from an airplane to help estimate the yield of a nuclear weapon. Having worked with Alvarez on this project, in mid-1945, Agnew was sent to Tinian Island—the base for the Hiroshima and Nagasaki missions—to help ready the bombs developed at Los Alamos and to oversee the deployment of the blast sensors during the bombings.

“We were working six days a week on Tinian, trying to get ready for the mission,” Agnew recalled. “We all got jungle rot on our feet and hands. I remember going to a doctor and asking what to do. He told me, ‘Scratch it.’”

To fly the Hiroshima mission, Agnew was required to wear a military uniform (with the logic that if the plane crashed and he were captured, he would be treated as a prisoner of war and receive better treatment than if he were thought to be a spy). Agnew was issued a quartermaster’s uniform, which, as

■ Agnew at Tinian Island with the plutonium core of the Fat Man bomb, which was detonated over Nagasaki, Japan, on August 9, 1945.



■ Agnew observed the Hiroshima mission from aboard a follow plane, the *Great Artiste*, and his camera was used aboard the bomber to film the only extant footage of the event. Agnew took this photo on Tinian Island of electrical engineer Walter Goodman with the *Great Artiste*—the only bomber to participate in the bombings of both Hiroshima and Nagasaki, Japan.

he discovered, earned him privileges on Tinian. “He went to the supply hut, and there were a couple of privates there who jumped up and saluted him,” Carr says. “And so, Harold started asking for stuff. He said, ‘Can I have a camera?’ and they said, ‘Absolutely.’ He said, ‘I’ve got to have some film for my camera,’ so they gave him some film.” But the privates’ willingness to accommodate Agnew only went so far: “Harold saw some beer in there, and he said, ‘Can I have that case?’ And the privates said, ‘We’ll have to ask the colonel about that.’”

From Tinian, on August 6, 1945, Agnew flew on an instrument plane, the *Great Artiste*, that accompanied the *Enola Gay*, which dropped the Hiroshima bomb. A third aircraft was tasked with filming the bombing, but Agnew smuggled the camera he’d acquired onto the *Great Artiste* and passed it to the bomber’s tail gunner, who would have a better view of Hiroshima than Agnew and who duly filmed the bombing. Agnew’s decision to bring a camera was fortuitous: The official camera failed, making the footage from Agnew’s camera the only extant video of the event.

Throughout his life, Agnew never expressed any doubt about the necessity of the Hiroshima and Nagasaki bombings. “By ending the war so quickly... we saved a lot of lives,” he said in 1983.

Agnew acknowledged that his thinking about the bombings was shaped by personal experience. “Many of my classmates were killed in the war. This had a bearing on my attitude,” he said. “These were real people that I had grown up with, played softball with... A whole bunch of guys that I went to school with were all killed.”

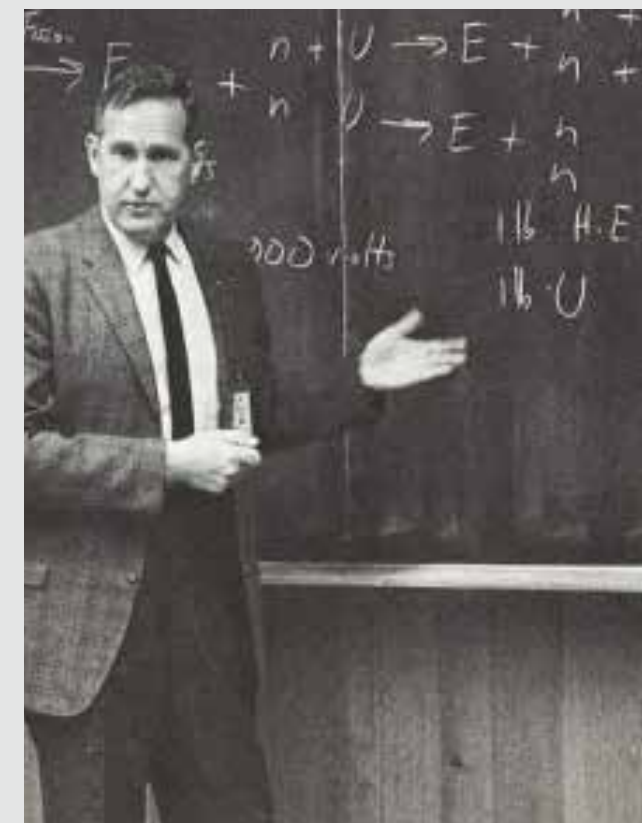

■ Beginning in the 1950s, Agnew ascended through the Laboratory’s ranks.



■ A collection of photos owned by Agnew that is today maintained in the Laboratory's National Security Research Center archives. Agnew was especially proud of a photograph that he took of his mentor, Nobel Laureate Enrico Fermi, in 1952 (inset, Agnew's handwriting on the back of the image).

Very Special
Best Photo of Fermi
ever taken. By
my negative
SAVE
Taken

"Agnew said that the bomb was the single best thing to happen in World War II," Meade says. "It stopped the war, and it stopped the killing. He was out in the Pacific, and he saw the carnage and the death—the hospitals that were being built to hold the wounded that would come back when Japan was invaded. I think that the Manhattan Project was really the thing that Agnew was most proud of."

Returning to the Laboratory

When the war ended, Agnew was just 24 years old. Although he'd played a part in the Manhattan Project, the war had interrupted his education, and his first order of business was to return to school and earn his doctoral degree. With backing from Fermi, Agnew was granted a fellowship to study physics at the University of Chicago. He moved with Beverly and their daughter, Nancy, to Chicago in 1946 and promptly took up residence in Fermi's home, where the Agnews remained until Harold was able to find an apartment for the family.

Although Agnew's background in chemistry made doctoral work in physics challenging, he was grateful for the opportunity to continue to work with Fermi, whom Agnew, like many scientists of his generation, viewed as a hero. In Meade's estimation, working closely with Fermi was the thing that Agnew took pride in most after his contributions to the Manhattan Project. "Agnew was very proud of his scientific character—of where he came from and who he was taught by," Meade says. "I think that exposure to Fermi is really what drove his career academically and intellectually."

Agnew's graduate work involved both experimental and theoretical research. For his thesis, he designed a two-coil beta-ray spectrometer, which, by measuring the energy and intensity of beta particles emitted during nuclear decay, could help characterize the disintegration of atomic nuclei.

With his doctorate in hand, in 1949, Agnew returned with his family to Los Alamos, where he secured a position that involved conducting research with a Van de Graaff accelerator. In a biographical memoir of Agnew published for the National Academy of Sciences, physicist Dick Garwin recounts an incident from this period that nearly cost Agnew his job:

The physicists [who were conducting research on the Van de Graaff] were contaminated by breathing tritium, and in order to remove it from the body as quickly as possible, they were instructed to drink beer all day at the Van de Graaff. Their urine samples were tested daily for tritium, and one day, Harold submitted a sample of beer rather than urine. Tom Shipman, head of the medical group, sent Jerry Kellogg, the Physics Division leader, a note saying that with that level of alcohol in his urine, Harold was probably dead.

Agnew responded to Shipman, "Members of Group P-3 (Accelerator Research) are unique individuals and ordinarily an alcoholic content of the order of 6% in their urine should not be considered as unusual." Kellogg was not amused and sought to have Agnew fired, but fortunately, the incident was forgotten.

It wasn't the only time that Agnew would, by his own account, put his job in jeopardy. A second such incident occurred a few years later, when Los Alamos' thermonuclear weapon program was in full swing.

The thermonuclear program

Although scientists at Los Alamos had conducted research into fusion—that is, the fusing of atomic nuclei, which can yield a far greater release of energy than fission can—since the earliest days of the Manhattan Project, fusion research began in earnest at the Laboratory after the Soviet Union detonated its first atomic device in 1949. In response, in 1950, President Harry S. Truman directed Los Alamos to continue, as quickly as possible, the development of a fusion weapon. The Laboratory adopted a six-day work week to achieve this goal.

In 1951, mathematician Stanislaw Ulam proposed an idea that physicist Edward Teller greatly improved upon to help make the design of a thermonuclear weapon possible. Experiments over the next several years confirmed Teller and Ulam's insights, ushering in the thermonuclear era. The earliest thermonuclear devices were built with deuterium (a hydrogen isotope) that had to be cryogenically cooled to around negative 423 degrees Celsius—cold enough to ensure that the deuterium remained liquid. This made the devices large and difficult to handle even after Los Alamos researchers endeavored to reduce their size.

Agnew, however, had a different idea. Rather than rely on liquid hydrogen, why not use a "dry," or solid, fuel? Weapons that used solid fuel could be smaller, lighter, and easier to maintain than liquid ones, although they would potentially have lower yields. "Harold felt that we were making too many bombs in too many ways and that if we really did want to have an emergency capability ready as soon as possible, the Laboratory needed to concentrate on the most straightforward, effective weapons," Carr says. "To him, that meant ditching all the cryogenic stuff. And he wanted to bring this idea to the attention of senior management at the Laboratory."

Later, Agnew attributed his support for solid-fueled weapons to a premonition. "I was obsessed with the idea that we could make [the weapons] much smaller, and the reason I wanted to make them smaller was so they could be compatible with missiles, which I was convinced was going to happen," he said in the 1980s. (The Honest John surface-to-air missile, which was deployed in 1953, was the first missile that could deliver a nuclear weapon. In 1959, the United States deployed the Atlas missile—the first intercontinental ballistic missile to enter service.)

To advance his vision for thermonuclear weapon development, Agnew decided to bypass his managers—including Marshall Holloway, who had led key thermonuclear research campaigns—and sent a letter directly to Bradbury, the

■ Agnew, third from left, prepares a meal with colleagues in the 1950s.



His vision made it possible to streamline fabrication and all the other aspects of weapon production that people don't usually think about.

—ALAN CARR

Laboratory's director. Agnew persuaded Hans Bethe, who had led Los Alamos' theoretical division during the war and would win the Nobel Prize in 1967, to sign a letter to Bradbury that concurred with Agnew's opinion.

The move was risky. Agnew later claimed that after the letter was sent, he was told that Holloway was furious and that he would have been fired if not for Bethe's signature on the letter. Not only did Agnew keep his job, however, but his vision won out, and Los Alamos consolidated its efforts behind the design of solid-fueled weapons. "Ultimately, Harold was proven right," Carr says. "His vision made it possible to streamline fabrication and all the other aspects of weapon production that people don't usually think about."

New approaches to nuclear safety

By the mid-1950s, Agnew had set his sights on the Laboratory's top job. "I couldn't think of anything better than running Los Alamos," he said later. (In this respect, he differed from Bradbury, who became director only reluctantly.)

Throughout the 1950s, Agnew continued to advance in Los Alamos' weapons program. He also ran for and was elected to the New Mexico State Legislature, representing the newly created Los Alamos County as a senator from 1955 to 1961. Beverly was elected to office, too, serving on the New Mexico Board of Education.

In 1960, Agnew made a somewhat risky decision: to accept a short-term assignment to the North Atlantic Treaty Organization's (NATO's) Joint Committee on Atomic Energy. The role necessitated a move to Paris from 1961 to 1964. "I really wanted to stay at Los Alamos because when you leave a place, you are forgotten," he said. "Leaving was rather traumatic."

Why, then, did Agnew go to Europe? "You had Bradbury sitting in the directorship for a long time. Division leaders were there for a long time. I think he was sort of champing at the bit," Meade says. "He saw that if he was going to get ahead, he had to get something else on his resume, and that



■ Agnew returned to Los Alamos after several years in Europe and was soon appointed leader of the Laboratory's weapons program.

was to go off to NATO as a science advisor. That experience gave him an entrée into a world that he might not otherwise have had."

While in Europe, Agnew had an experience that led him to propose a technical innovation that still supports nuclear weapon safety today. Carr recounts that while visiting an air base that hosted American nuclear weapons under NATO, Agnew was aghast to discover that the weapons were guarded by a lone soldier with a rifle whose job it was to prevent the unauthorized takeoff of any aircraft carrying American nuclear weapons.

"Agnew thought that we should have something more to protect those weapons," Carr says. "And that was the origin of the permissive action link."

The permissive action link, or PAL, requires the input of a code that "unlocks" a weapon for use. Agnew brought the idea to researchers at Sandia National Laboratory (today's Sandia National Laboratories), which designs nuclear weapons' nonnuclear components and took the lead on developing the PAL. In 1962, at the direction of President John F. Kennedy, PALs were installed on all American nuclear weapons in Europe, and over the following two decades, PALs would be incorporated into all U.S. nuclear weapons.

Agnew played an important part in other aspects of nuclear weapon safety research, too, having helped author the technical guidance that underpins what came to be known as the Walske Criteria. The Walske Criteria, which were proposed in 1968 by Carl Walske (then assistant to the secretary of defense for atomic energy), comprise a set of safety requirements for nuclear weapon designs. Per the Walske Criteria, every weapon in the U.S. stockpile must have no greater than a one-in-a-billion chance of an accidental detonation over its lifespan and no greater than a one-in-a-million chance of an accidental detonation under conditions such as airplane crashes or fires.

The criteria also include one-point safety, according to which the likelihood of significant nuclear yield resulting from a detonation of the high explosives inside a nuclear weapon at any single point must be less than one in a million. "The creation of the Walske Criteria really goes back to Harold Agnew and other people who worked in the weapons program at Los Alamos in the 1950s," Carr says.

Becoming director

Agnew's gambit in leaving the Laboratory paid off: When he returned to Los Alamos in 1964, he was appointed leader of the weapons program. Five years later, Bradbury retired as Laboratory director, and in 1970, Agnew at last took Los Alamos' top job. Although Agnew offered Bradbury a position as a senior advisor to the director, Bradbury declined:

"[Bradbury] said, 'You wanted it, you got it,'" Agnew recalled. "I guess he felt that I knew what I was doing."

Even without Bradbury's guidance, Agnew didn't want for confidence. Nuclear physicist John Hopkins started at the Laboratory as a student in 1955, and over the course of some four decades at Los Alamos, he would come to direct its testing and weapons programs. Hopkins worked closely with Agnew and became a friend of the director, whom he views as one of the Laboratory's three greatest leaders (alongside Oppenheimer and Bradbury).

"Agnew and Bradbury both came up through the weapons program, so they understood nuclear weapons," Hopkins says. "They were both very confident in their positions, which made them easy to talk to and easy to disagree with. And they respected their staff. If anybody at the Laboratory wanted to talk to Harold about something, they were welcome in his office."

Hopkins notes that one of Agnew's first decisions as director was to change many of the leaders of the weapons program. Leaders such as J. Carson Mark, who had played an important part in the thermonuclear program, and Jane Hall, an associate director of the Laboratory, were encouraged to retire or otherwise give up their leadership positions as Agnew hired staff who more closely shared his vision for Los Alamos' future.

■ Agnew with Norris Bradbury, whom Agnew succeeded as Los Alamos' director.





■ Agnew with Laboratory visitors and Louis Rosen (right), who was instrumental in developing the Los Alamos Meson Physics Facility (today's Los Alamos Neutron Science Center).



■ Minister Billy Graham visited Los Alamos in the 1970s (Graham's sister-in-law lived in Los Alamos and was married to a Laboratory employee).



■ Agnew speaking at Los Alamos in the 1970s.

In 1983, Raemer Schreiber, who was deputy Laboratory director under Agnew, explained that although Bradbury had foreseen the need for changes in Los Alamos' leadership and organization, he had decided to let his successor make those changes. "Norris did not want to make changes that would obligate the incoming director," Schreiber said. "When Harold took over, he had the chance to assert his leadership at once."

Nuclear weapons under Agnew

Agnew soon asserted his leadership in other ways, too. In 1952, Lawrence Livermore National Laboratory was founded in California as a second nuclear weapons-design laboratory. Although Livermore suffered early setbacks in its weapons development, throughout the 1960s, the laboratory distinguished itself by its willingness to innovate and by its eagerness to cultivate relationships with the military.

Carr says that Agnew's attitude toward innovation was one of the reasons that Agnew was the right choice to be Bradbury's successor. "Bradbury was extremely conservative in many ways," Carr says. "I think that was of great value to the weapons program for a long time. His attitude was, 'We're not building science-fair projects. We're building weapons. And if you build a weapon for deterrence, it has to work.' But in the early 1960s, Livermore began to really take off and to come up with some incredibly innovative weapon designs. And Los Alamos was falling behind. We weren't being as can-do as we needed to be."

With Agnew as director, Los Alamos adopted a more adventurous and collaborative approach to weapons development. "Harold was much more enthusiastic than Bradbury about trying new ideas," Hopkins says. "If you came to Harold with a fancy new idea, he'd be more likely to accept it than Bradbury would have been."

This attitude was especially important at a time when the nation's deterrence strategy increasingly emphasized land-

"We're not building science-fair projects. We're building weapons. And if you build a weapon for deterrence, it has to work."
 —ALAN CARR, PARAPHRASING HAROLD AGNEW



■ Agnew with his former colleague Edward Teller.

and sea-based ballistic missiles over bombs delivered by aircraft. Such weapons necessitated greater collaboration between the laboratories, which designed the warheads, and the military, which designed the missiles on which the warheads were delivered.

For this reason, a closer relationship between the Laboratory and the military was essential. Agnew created a new office at the Laboratory that was responsible for coordinating with the military. He also lobbied vigorously in Washington, D.C., on Los Alamos' behalf, emphasizing public relations in a way that Bradbury hadn't.

Beyond reflecting a different attitude about the Laboratory's role, Agnew's efforts to acquire new weapon programs for Los Alamos (such as the W76 for Trident submarine-launched ballistic missiles and the W78 for Minuteman III intercontinental ballistic missiles) arguably reflected a different attitude toward nuclear weapons in general. "Harold was a weapons guy," Carr says. "Harold was fascinated with weapons. He liked the technology, and he always wanted to push the limits. He warmly embraced nuclear deterrence."

This attitude may go some way toward explaining Agnew's support for more controversial weapon designs. For example, Agnew advocated for the development of tactical nuclear weapons—nuclear weapons with a small yield that could be used on the battlefield. He also supported the

development of the so-called "neutron bomb," also known as the enhanced-radiation weapon, which would have maximized the production of short-term radiation while minimizing blast and radioactive fallout.

At the same time, weapons safety remained a priority for Agnew. One of the achievements of which he was most proud was Los Alamos' development of insensitive high explosives for nuclear weapons. Insensitive high explosives can be struck with a bullet without detonating and are less likely to ignite in a fire, and they are widely used in the U.S. nuclear weapon stockpile today.

The Laboratory diversifies

Although Agnew revitalized the Laboratory's weapons program, he was also eager to expand Los Alamos' work into new areas. Under Bradbury, the Laboratory had conducted research into technologies that were related to nuclear physics—for example, controlled thermonuclear fusion and nuclear-powered rockets. But it was only under Agnew that major research programs in areas with little or no connection to nuclear science first came to fruition.

"[Agnew] was always intensely proud of the capabilities of the Laboratory and did not feel that its expertise needed to be confined to nuclear physics," Schreiber said. "He was willing to tackle any scientific or technological problem worth solving. Generally, he took the attitude, 'If we don't have the experts, we can get them.'"



■ Agnew was a frequent visitor to the Laboratory even in the final years of his life.

Energy research quickly became a major focus at Los Alamos. Since the Manhattan Project, the Laboratory had conducted research related to nuclear reactors. Among other projects, Rover—which involved developing nuclear-powered rocket engines—became a major initiative at Los Alamos in the 1960s.

However, in 1973, the Atomic Energy Commission, which oversaw Los Alamos, ended Rover. Partly out of a need to find new work for the scientists and engineers who had formerly conducted this research—and, a few years later, in response to the oil crisis of 1973–1974, which increased national interest in alternative energy sources—under Agnew, the Laboratory expanded its solar energy, hydrogen fuel, and geothermal research. Los Alamos soon carried out pioneering research in each of these areas, and the Laboratory developed research programs in areas such as biology, applied mathematics, and earth sciences such as hydrology and atmospheric modeling, too.

Other programs had a more direct connection to nuclear science. Under Bradbury, the Laboratory had established a nuclear safeguards program, which involved developing tools that would allow workers and safeguard inspectors to monitor facilities where nuclear material was handled, ensuring that such material wasn't stolen or diverted. Agnew endorsed this program, and while he was director, the Laboratory continued to support the International Atomic Energy Agency (IAEA). As the world's foremost developer of safeguard instruments, Los Alamos also began to train IAEA inspectors on the use

of these tools. Since Agnew's tenure, every IAEA safeguard inspector has come to the Laboratory for training.

Under Agnew, in 1972, Los Alamos also opened a kilometer-long particle accelerator called the Meson Physics Facility, which is known today as the Los Alamos Neutron Science Center, to conduct important basic physics research. (The project was inaugurated under Bradbury.) And, while Agnew was director, the Laboratory acquired its first Cray supercomputer—a machine that would set the stage for later supercomputing research at Los Alamos (an area that remains central to the Laboratory's work today).

So successful was Los Alamos' expansion into new areas that during Agnew's tenure as director, the Laboratory roughly doubled in size, growing from some 4,000 to 8,000 employees. Throughout this period, Agnew remained a highly engaged leader who would often visit employees personally. "He had a certain number of things he'd want to accomplish in a day, and if he got through that list, he'd often wander around, dropping into people's offices and saying, 'What are you doing? How are things going?'" Hopkins says. "It was nice to know that if anybody wanted to talk to Harold about something, they could."

Bureaucracy blues

During the mid-1970s, more stringent oversight from Washington, D.C., led to bureaucratic constraints for which Agnew had little patience. For example, as the environment became a matter of increasing public concern, environmental stewardship began to be taken more seriously in the nuclear enterprise. A consequence of this shift was the introduction of additional oversight and paperwork that, in Agnew's view, hindered Los Alamos' work. "Harold was a guy who'd built the world's first nuclear reactor with his own hands," Carr says. "And his attitude was, 'Now, we're having to do all this paperwork just to do something we've done a million times before.'"

Agnew wasn't afraid to express his contempt for new bureaucratic hurdles. "Bureaucracy will eradicate creative endeavor and innovation in the long run," Agnew said in a statement delivered to the National Science Board in 1976. "Unless this trend toward centralization is somehow reversed, I predict the U.S. will rapidly lose its lead in science and technology."

Statements like these contributed to Agnew's stature at the Laboratory, where he was seen as a defender of science and Los Alamos' work. But they also created tensions with Washington and with the University of California, which, since the Manhattan Project, had been contracted to operate the Laboratory.

Fed up with bureaucratic hurdles and what he perceived as a lack of institutional support, Agnew resigned the directorship in 1979. Hopkins recalls asking Agnew why he chose to quit. "He said he woke up one morning, and he was pissed off at everybody. And so, he thought that was the time to leave," Hopkins says.

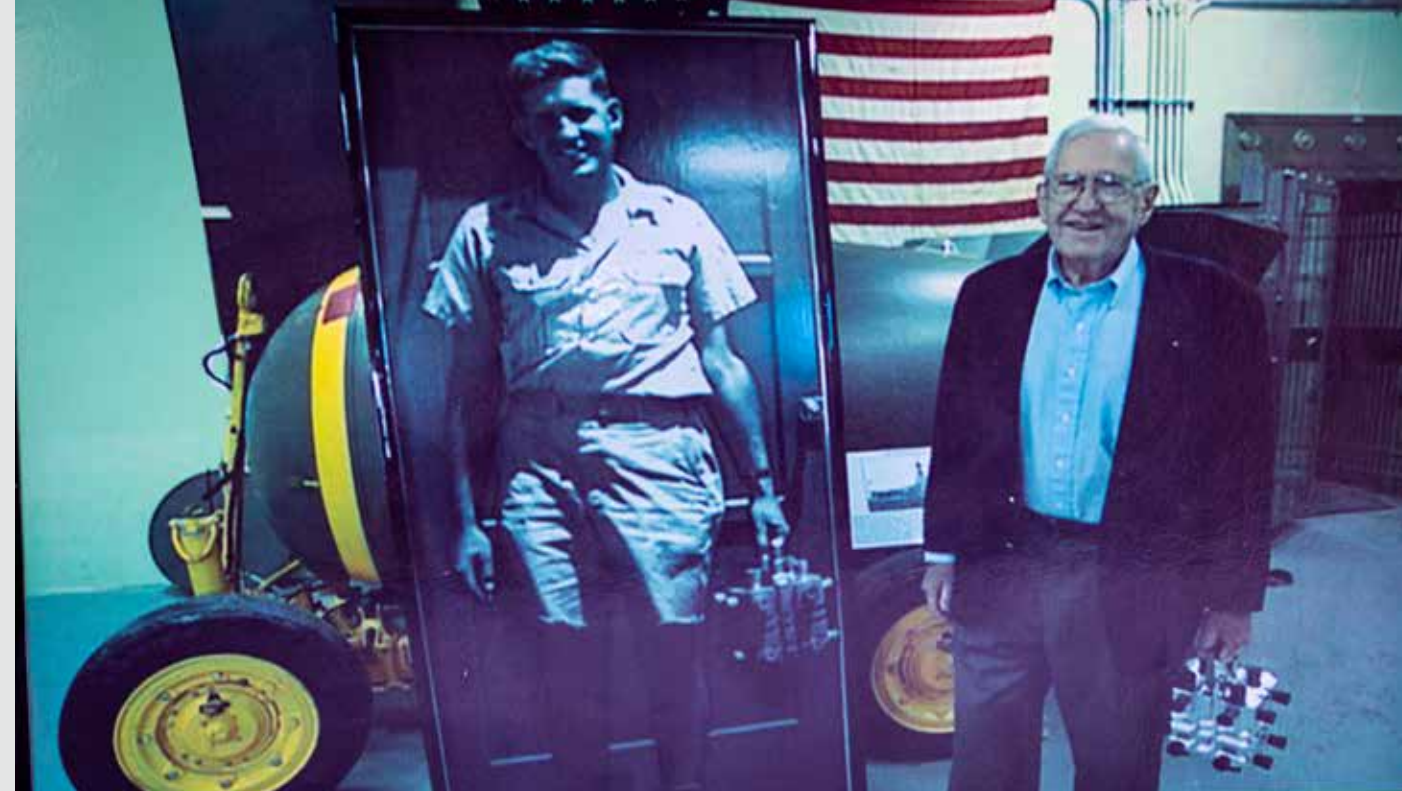

■ In 2006, Harold Agnew posed beside a famous photo taken of him on Tinian Island in 1945. In the 1945 photo, Agnew carries the plutonium core of the Fat Man bomb.

Later, Agnew would be more circumspect. In 2005, discussing Bradbury's 25-year tenure at the Laboratory and, implicitly, reflecting on his own career, Agnew said, "If you take a leadership job, if you can hack it, you ought to stay 5 years but no more than 10, because there are things you want to do and you've either done them or you haven't done them in 10 years. [If the latter,] you're never going to get them done, and you're out of ideas. So, let somebody else take over."

Life after Los Alamos

After leaving Los Alamos, Agnew became president of General Atomics in La Jolla, California. The company develops commercial nuclear power reactors and researches other nuclear technologies. Agnew remained the company's president until retiring in 1985, although he joined its board of directors in 1988, serving in that capacity for 25 years. He also became, in 1988, an adjunct professor at the University of California, San Diego, teaching in the physics department. He was elected to the National Academy of Engineering in 1976 and to the National Academy of Sciences in 1979.

Having retired to Solana Beach, California, Agnew made periodic visits to Los Alamos, where he regaled audiences with stories from his long career and where he remained a legendary figure. "Harold was very human. He was very approachable, and he was kind to everybody that I ever saw him interact with," Meade says. "But he was also larger than life. He knew a good story and a good piece of theater when he saw it. And people at the Laboratory felt that he was on their side and was speaking for them."

Beverly died in October 2011 after a period of ill health, during which Agnew had been a devoted caretaker. Agnew

himself lived until September 2013, when, at age 92 and while watching football on television, he died of leukemia. He was survived by his two children, Nancy and John, and their families.

Throughout his life, Agnew remained a staunch proponent of science in the national interest and of nuclear deterrence. As a witness to many of the most pivotal events of the nuclear age, he brought a singular perspective to Los Alamos and beyond.

"To me, what it all comes back to is that Harold loved this country," Carr says. "He believed in nuclear deterrence, and he wanted to make sure that the United States maintained its lead for the sake of the world. That's what drove him. He could be intimidating because of his candor, but that was because he cared about the Laboratory and wanted people to understand how important its mission was." ★



■ The Agnews are buried in Guaje Pines Cemetery in Los Alamos. Photo: Mark Chadwick



■ In June 1999, Manny the crane lifted the 287,000-pound, 10-meter-diameter NIF target chamber out of the steel tank in which it was constructed and into the NIF target bay. The NIF building was then completed around the chamber. Photos: LLNL

FROM NEVADA TO NIF AND BEYOND

One of the world's largest cranes makes its way around the country in support of national security.

BY WHITNEY SPIVEY

Manny, a Manitowoc 4600 ringer heavy-lift crane, is 14 stories tall, weighs 1,000 tons, and has a 320-foot boom (arm). Manny can lift 600 tons—that's 1.2 million pounds. Now in his early forties, Manny has spent the bulk of his career in service to the country. Here's a quick look at his contributions:

Nevada National Security Sites

The Department of Energy purchased Manny in 1983 for \$3.4 million. He spent the first 19 years of his life lifting and lowering experiments into place at what is today the Nevada National Security Sites. The data from these experiments was used (and still is used) to inform the assessment of the nuclear stockpile. When the United States halted such experiments in 1992, Manny sat idly at the site of Icecap, a Los Alamos-designed experiment that never happened. "Manny stood patiently by the ICECAP tower, waiting to swing into action," according to an article in *Newsline*, Lawrence Livermore National Laboratory's weekly newsletter. "He remained there idle for seven years. His metal muscle and steel sinew sagged unflexed, as the desert sun bleached his paint and tufts of rust blossomed on his boom."

Lawrence Livermore National Laboratory

A total of 66 trucks were necessary to relocate Manny from Nevada to California, where he played an essential role in the construction of the National Ignition Facility at Lawrence Livermore National Laboratory. In June 1999, Manny hoisted a 287,000-pound, 10-meter-diameter target chamber out of the massive oil tank where it had been assembled. Manny lowered the chamber into NIF's target bay, and the NIF building was completed around the chamber. *Newsline* reported that "at Livermore, Manny emerged immediately as a big man on campus," performing more than 250 power lifts in addition to helping out at NIF. According to Livermore rigging engineer John Reed, "just a few percent of mobile cranes of Manny's generation worldwide have his reach and capacity. He's big, he's powerful, he's safe."

Oak Ridge National Laboratory

After NIF's completion, *Newsline* reported that "In a career that has lifted millions of pounds—and millions of dollars—of technology, it was time again for Manny to move on to a place where his gargantuan size and Herculean strength could be put to use." And so, in 2002, Livermore relinquished Manny—for free except for shipping costs—to Oak Ridge National Laboratory in Tennessee. The cross-country trek required more than 60 trucks, including nearly a dozen 9-axle trailers. Manny—now with a new name: Big Bertha—was used for heavy lifting during construction of the Spallation Neutron Source, an accelerator-based neutron source facility that was completed in 2006.

Where is Manny now?

According to Oak Ridge National Laboratory, Manny was sold around 2015. His current whereabouts are unknown, although rumor has it he is working in the oil industry on the Louisiana bayou. If you have insight into Manny's location, please email magazine@lanl.gov. ★

A MAMMOTH CAREER

Physicist Jeff Paisner's 52 years in the nuclear security enterprise includes overseeing the early construction of the National Ignition Facility.

BY WHITNEY SPIVEY

In 1992, physicist Jeff Paisner was serving as deputy associate director of the Atomic Vapor Laser Isotope Separation Programs at Lawrence Livermore National Laboratory when he was asked to help stand up the National Ignition Facility (NIF)—an ambitious capability intended to advance inertial confinement fusion and deepen our understanding of the universe. Despite being on vacation at Disney World with his wife and three-year-old daughter, Paisner accepted the challenge. From 1993 to 1999, he served as NIF's project manager, overseeing core technology development, systems architecture, overall engineering design, and the early construction phases of NIF.

"The launching of NIF was graced by many miracles spanning people, partnerships, politics, science, technology, and engineering," says Paisner, who has worked at Los Alamos National Laboratory since 2003.

Many of the "miracles" Paisner recalls were technical (such as adjusting configurations in the face of strong opposition) or political, including securing timely support and approvals from policymakers. Others, however, were environmental—and perhaps unsurprising given the excavation of a 500,000-square-foot facility.

Early in construction, crews unearthed highly toxic polychlorinated biphenyl-laden capacitors. Ironically, the capacitors had been

used for Astron, a fusion power device pioneered by physicist Nicholas Christofilos in the 1960s and 1970s. After what Paisner describes as a "rapid and compliant dispositioning" of the capacitors, construction resumed—only to stall again in the fall of 1997, when a rainstorm devastated the site and required extensive repairs to the foundation.

Just months later, construction crews made an even more unexpected discovery: the jawbone of a Pleistocene-era mammoth. "All work was halted and a field paleontologist quickly hired," Paisner recalls. "Despite an agonizingly slow excavation and preservation process, construction of the building started back up by the New Year and proceeded apace—and, amazingly, on schedule."

Now, three decades later, and after a career spanning two national laboratories and leadership roles spanning hydrodynamic test programs and subcritical experiments, Paisner looks back fondly on NIF's early days. "The lightning speed at which NIF was launched is a testament to the project team, partner laboratories, and exceptional leadership at all levels," he says. "Their incredible teamwork and esprit de corps enabled extraordinarily high productivity. NIF was—and still is—founded on an unwavering commitment to excellence, innovation, and passion for science. I will always feel grateful and proud to have been part of the NIF story." ★

■ Around 2021, Mike Campbell, then the director of the Laboratory for Laser Energetics at the University of Rochester, drew this caricature of Paisner.

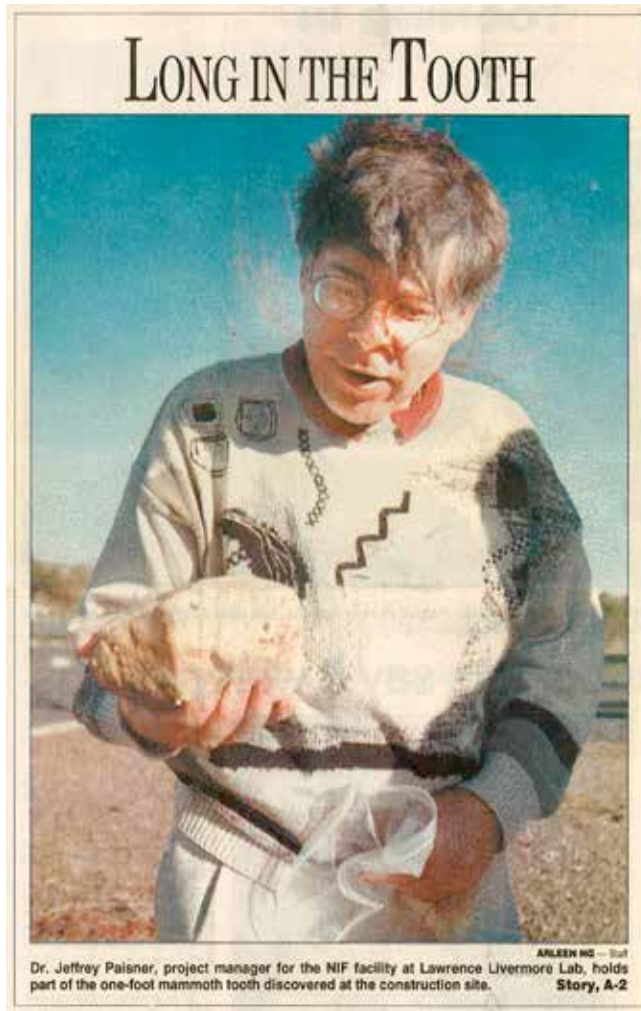
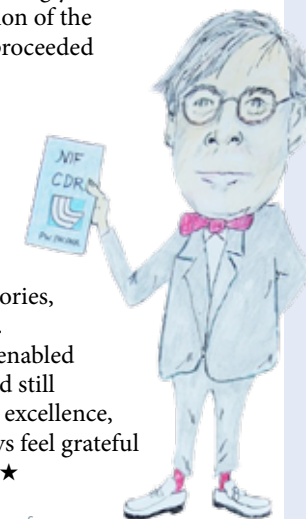

Dr. Jeffrey Paisner, project manager for the NIF facility at Lawrence Livermore Lab, holds part of the one-foot mammoth tooth discovered at the construction site. *ANISEN HG — Staff Story, A-2*



■ Verena and Hermann Geppert-Kleinrath



■ Verena ties flies at her kitchen table.

THE SOUND OF FUSION

For an Austrian couple working as physicists at Los Alamos National Laboratory, the hills are alive.

BY MAUREEN LUNN

Nestled at the base of the Jemez Mountains in Los Alamos, New Mexico, is a modern home filled with German conversation and the aromas of traditional Austrian cooking. Inside, the walls display a mix of Southwestern art and physics awards—many physics awards.

The owners of the custom-built home are Hermann and Verena Geppert-Kleinrath, who both work in Los Alamos National Laboratory's Physics division. Hermann specializes in diagnosing fusion ignition experiments, and Verena is a manager in the Dynamic Imaging and Radiography group.

At the end of their workdays, they pick up their two kids from school—often by bicycle—and return home to their two cats, Pico [the] Second and Alpha Burn. At the slightest hint of chill in the air, they light a fire and prepare a meal inspired by their Austrian roots: hearty dumplings, potato soup, or Viennese beef broth.

Cycling and cooking sustain their daily rhythms, but their list of hobbies is long and varied. They camp, hike, hunt, fish, row, build boats, practice woodworking, knit, 3D print, cross-country ski, downhill ski, repair furniture, sew, and

occasionally fence. They even built their own teardrop camper and recently enrolled in a beginner pottery class.

And the ping-pong table on their back patio? They are quick to clarify: table tennis isn't a hobby—"it's a lifestyle."

CAREER DEVELOPMENT

Hermann and Verena met at the Vienna University of Technology, where they both studied physics. Verena came to the United States in 2011, first as a graduate student at Idaho State University before moving to Los Alamos in 2013. At the time, Hermann was finishing his studies in quantum physics. When he followed Verena to Los Alamos, his career took an unexpected turn.

That turn happened on the ski slopes of Pajarito Mountain, where Verena volunteered on ski patrol. Among her fellow patrollers were Lab physicists. Through those connections, Hermann was introduced to—and soon recruited by—a team studying fusion diagnostics.

Both Verena and Hermann have since built a career in inertial confinement fusion, developing advanced nuclear diagnostics to capture and interpret fusion data. Verena led the development and operation of the Neutron Imaging System (NIS) at the National Ignition Facility (NIF). NIS records hot spots and instabilities within a fusion reaction, providing critical insight into the limits of performance by analyzing the 3D shape of the implosion.

Hermann supports research at both NIF and the Omega Laser Facility at the University of Rochester. He leads the team operating the Gamma Reaction History diagnostic, an instrument that measures the fusion rate over time with unprecedented precision—down to picoseconds—offering detailed information about the timing of a reaction.

Hanging in the Geppert-Kleinrath's home office are two Secretary of Energy Achievement Awards, recognizing their individual contributions to the "lasers, diagnostics, targets, and physics understanding" that led to the historic fusion ignition at NIF in August 2021.

"When the ignition shot happened, it was incredibly exciting," Hermann says. "Just a day earlier, we were having lunch with one of our research students and talking about how long we'd been chasing fusion. It always seemed just out of reach. We thought we might never achieve it. The next day, we got word that it had happened."

Verena notes that more than 1,000 scientists were named in the publication describing that first ignition shot—a testament to the complexity and collaboration behind the breakthrough. "Every one of those people working together is what made it

happen," she says. "They're the brightest and best in the field. It was extremely cool to be part of."

BEYOND IGNITION

After contributing to one of the defining scientific milestones of their generation, the couple didn't slow down. Outside of work, they built a home with a woodshop and in March 2025, moved in. Verena gestures to a small, rustic wooden spoon resting on the dining table. "This was my first woodworking project," she says. "After that, I carved a small fox."

Hermann traces his woodworking roots to childhood in Austria. "My grandfather told me carving is easy," he recalls. "If you want to carve a fox, just cut away all the wood that's not a fox."

Now Hermann is fabricating two rowboats—his and hers—with plans to spend more time on nearby lakes. Verena is equally content along the shore, where she has cultivated a love of fly fishing.

Living in a small mountain town, they say, has enriched their lives with both community and adventure. "We found a really special community here," Verena says. "It's both science-minded and adventurous. We can work hard and live life to the max." ★

■ Pico the cat supervises as Hermann canes a chair.



ACHIEVEMENTS OF LOS ALAMOS EMPLOYEES

During a visit to Los Alamos in February, National Nuclear Security Agency (NNSA) Administrator Brandon Williams and Department of Energy Under Secretary for Science Darío Gil recognized dozens of Lab employees for their work related to the safe processing and offsite shipment of four challenging flanged tritium waste containers that had been on site for years. The employees received the NNSA Administrator's Distinguished Service Silver Award, and their contributions were noted as being in service to the public and environment by mitigating potential hazards—and as being vital to the national security mission.

Two Theoretical division researchers each won an Early Career Research Award from

the Department of Energy's Office of Science, which provides five years of funding for a mission-centric research and development project. The winners and their research projects are **William Taitano**, who is formulating a simpler way to solve the Boltzmann equation, which could lead to better, more reliable transport simulations; and **Ingo Tews**, who is developing new models of nuclear interactions and using artificial intelligence to improve quantum simulations to better understand neutron stars and their mergers.

Anna Llobet was a recipient of the 2026 Women in Tech Awards from the New Mexico Technology Council. Llobet is a senior experimental physicist with more

than 30 years of research experience. She is the founder and coordinator of the annual New Mexico Summer Physics Camp, a free program designed to encourage students to pursue careers in STEM fields and engage with the national laboratories.

Two members of the Laboratory's Richard P. Feynman Center for Innovation were honored with 2026 Federal Laboratory Consortium Awards for outstanding achievements in technology transfer. **Kathleen McDonald** won an Outstanding Technology Transfer Professional Award for her leadership, and **Marc Witkowski** won an Excellence in Tech Transfer Award for advancing hydrogen fuel cell technology. ★

A SPECIAL THANKS

Recently retired Deputy Laboratory Director for Weapons **Robert (Bob) Webster** was named a Los Alamos National Laboratory Senior Fellow, one of the highest honors the Laboratory bestows upon its scientific and technical leaders. "Bob Webster represents the very best of Los Alamos National Laboratory," says Laboratory Director Thom Mason. "His transformative contributions across our national security mission—from

plasma physics to plutonium operations—strengthened our role as a design and production agency and helped restore pit production vital to the nation's deterrent. We are deeply grateful for his decades of service and lasting impact."

Webster came to the Laboratory as a graduate student in 1984. He became a staff member in 1989 and advanced through multiple technical and management positions, culminating in leadership of the Los Alamos Weapons program, a position

he held from 2015 to his retirement in March 2026. In this role, he directed the integration and execution of weapons design, production, and physics capabilities, ensuring the continued safety, reliability, and performance of the U.S. nuclear stockpile in support of national defense.

In addition to Webster's steady leadership and service to the nation, the *National Security Science* staff is deeply appreciative of Webster's support of this magazine. Bob, we wish you all the best in retirement! ★



BETTER SCIENCE = BETTER SECURITY

Hardworking people—the Laboratory's most important asset—enable Los Alamos to perform its national security mission.

50 YEARS AGO

To mark the 200th birthday of the United States, "drums beat, horns blared, and bells rang in Los Alamos during Fourth of July weekend as residents turned out in droves," according to *The Atom* magazine, which featured this image on the cover of its July-August 1976 issue. "Los Alamos is a unique community in many ways," the caption stated. "Yet, in other ways, it is just like thousands of other communities across the land. Two of these ways are its pride in our country and its unabashed enjoyment of parades and all the other events connected with a bang-up Fourth of July celebration."

Mathew Maltrud is the 13-year-old pictured playing the drum as he walks around Ashley Pond in downtown Los Alamos. "It was really fun being part of the bicentennial celebrations," he recalls. "As a junior high kid, it was a tremendous honor and also quite scary to perform with the high school band, especially with some drummers who I idolized." Just six years later, Maltrud would begin working at the Laboratory as an undergraduate student studying computational fluid dynamics. He worked on high-performance earth-system modeling until his retirement in 2024. ★

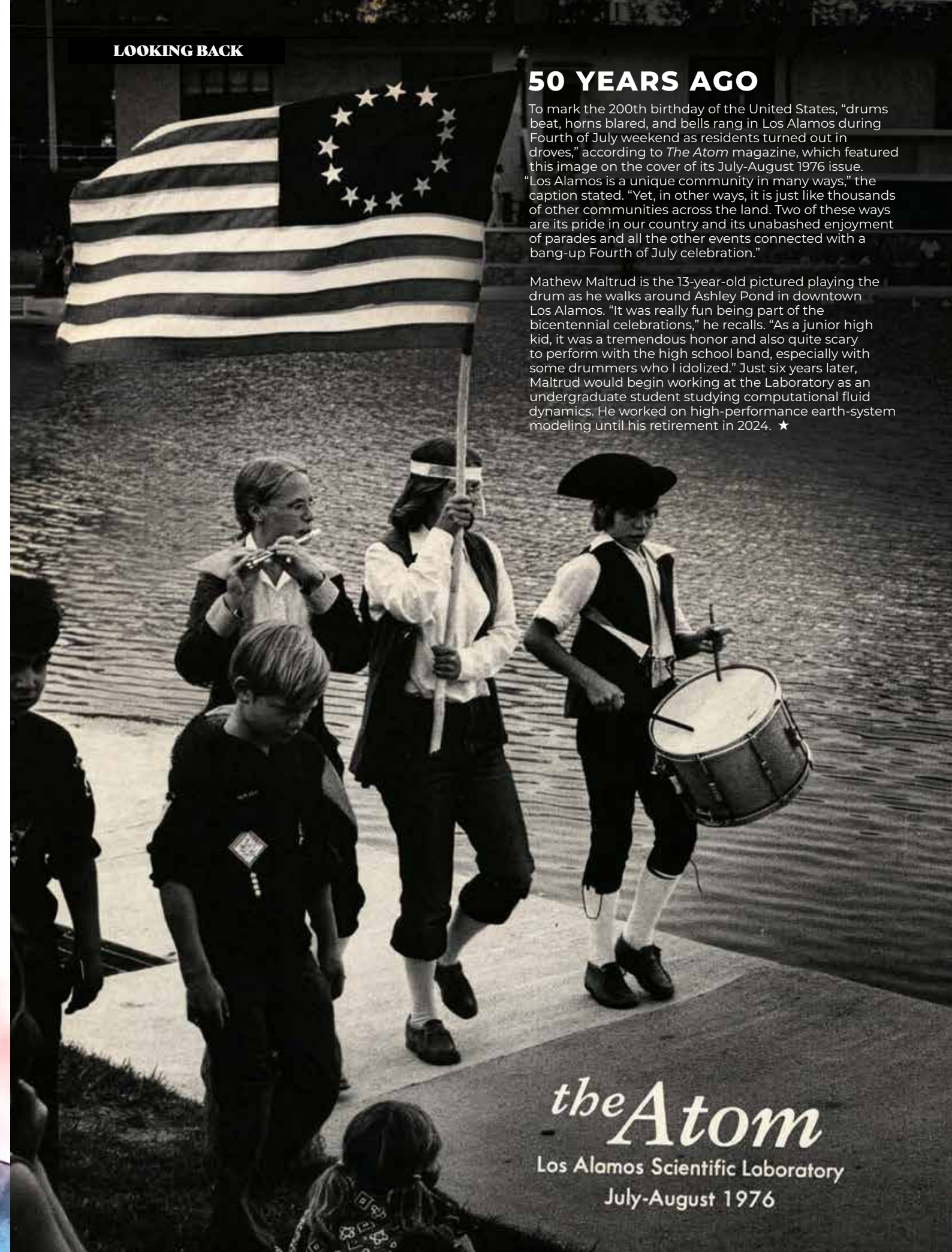

the Atom
Los Alamos Scientific Laboratory
July-August 1976

THEN & NOW

Adam Atchley, a hydrologist in Los Alamos National Laboratory's Energy and Natural Resources Security group, floats down the Dolores River in western Colorado.

Left, Los Alamos scientist James Tuck smokes a pipe as he captains a raft on Ashley Pond in downtown Los Alamos in June 1959. In the 1950s, Tuck designed, built, and tested the first toroidal magnetic fusion pinch machine, named the Perhapsatron. Learn more about early fusion research at Los Alamos on p. 26. ★

Rub A Dub Dub, Four Men In A Tub . . .



...AND WHO DO YOU THINK THEY MET Jim Tuck (with pipe), his son, Peter, T Division's Tom Dooler and Mike Werthamer (with glasses) put out to sea one night this month to collect data on Ashley Pond for the pond committee's report. The findings: Maximum dimension, 250 feet; present water content, 700,000 gallons; water analysis, practically neutral (pH 7.80) and suitable for propagation of fish.

